

BHARAT INSTITUTE OF ENGINEERING AND TECHNOLOGY

(Approved by AICTE Affiliated to SCTE & VT)

Sivaram Vihar, Ghatakeswar Hills, Mohada, Berhampur, Odisha.

PIN-760002



LECTURE NOTES ON SWITCH GEAR AND PROTECTIVE DEVICES

Prepared By
Er. Srinibasa Panda

DEPARTMENT OF ELECTRICAL ENGINEERING
BIET, MOHADA, BERHAMPUR



<http://www.biet.edu.in/>

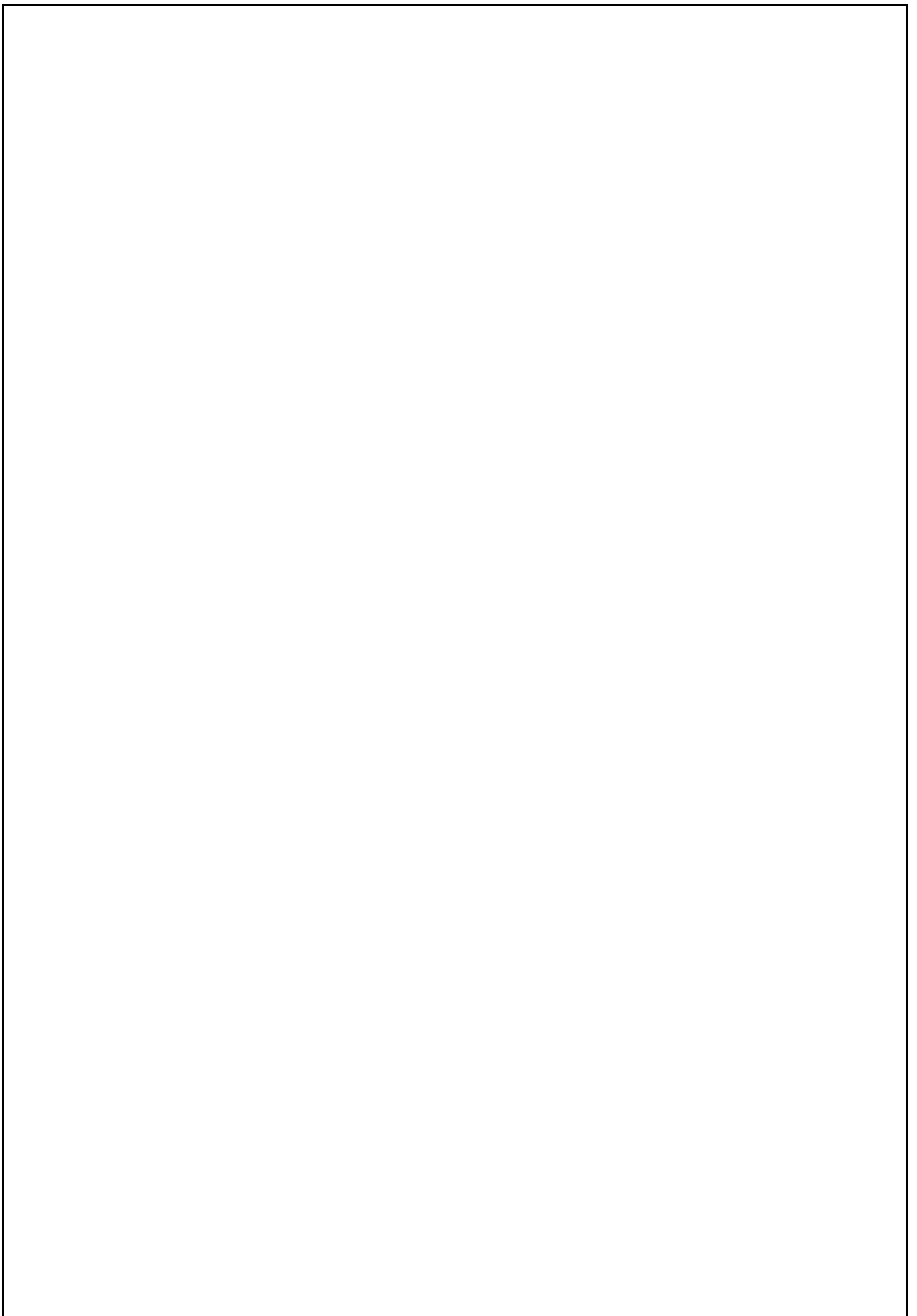

Course Details

NAME OF THE COURSE: Diploma in Electrical Engineering

Course Code	EET 601	Semester	6th
Total Period	60	Examination	3 hrs
Theory periods	4P / week	Class Test	20
Tutorial:	1p/week		
Maximum marks	100	End Semester Examination	80

- A. RATIONALE: Switch gear and protection plays an important role in the protection of electrical power system. Since the demand of electrical power is increasing the job of generation, transmission & distribution of electrical energy is becoming very completed. To maintain the energy supply to the consumer switching producer with protection is to be maintained moreover new models of switch gear and protection circuits are also being developed. The use of interconnection bus with National power grid type of switch gear and protecting devices need to be trained in proper manners. In the subject information on above context has been included so that the updated knowledge can be given to the students of Diploma in Electrical Engineering.
- B. OBJECTIVE: To acquire the knowledge of : a) The basic principles of protection of alternator transformer and feeders. b) Fuse and Circuit breaker. c) Protective Relay. d) Lighting Arrestor. e) Calculation of symmetrical fault current.

C. TOPIC WISE DISTRIBUTION OF PERIODS:

SL No.	Topics	Periods
1	Introduction To Switchgear	6
2	Fault Calculation	10
3	Fuses	5
4	Circuit Breakers	10
5	Protective Relays	10
6	Protection Of Electrical Power Equipment And Lines	6
7	Protection Against Over Voltage And Lighting	7
8	Static Relay	6
9	Total	60

Chapter I

Introduction to Switchgear

Switchgear covers a wide range of equipment concerned with switching and interrupting currents under both normal and abnormal conditions. It includes switches, fuses, circuit breakers, relays and other equipment. A brief account of these devices is given below. However, the reader may find the detailed discussion on them in the subsequent chapters.

- Definition: The apparatus used for controlling, regulating and switching on or off the electrical circuit in the electrical power system is known as switchgear.
- Switchgears are necessary at every switching point in the power system because there are several voltage levels and fault levels which has to be controlled and protected by accessible switching devices and for isolation, if the need arises.

Features of Switchgear:

The essential features of switchgear are :

1. Complete reliability: With the continued trend of interconnection and the increasing capacity of generating stations, the need for a reliable switchgear has become of paramount importance. This is not surprising because Switchgear is added to the power system to improve the reliability. When fault occurs on any part of the power system, the switchgear must operate to isolate the faulty section from the remainder circuit.
2. Absolutely certain discrimination: When fault occurs on any section of the power system, the switchgear must be able to discriminate between the faulty section and the healthy section. It should isolate the faulty section from the system without affecting the healthy section. This will ensure continuity of supply.
3. Quick operation: When fault occurs on any part of the power system, the switchgear must operate quickly so that no damage is done to generators, transformers and other equipment by the short-circuit currents. If fault is not cleared by switchgear quickly, it is likely to spread into healthy parts, thus endangering complete shutdown of the system.

4. Provision for manual control: A switchgear must have provision for manual control. In case the electrical (or electronics) control fails, the necessary operation can be carried out through manual control.

5. Provision for instruments: There must be provision for instruments which may be required. These may be in the form of ammeter or voltmeter on the unit itself or the necessary current and voltage transformers for connecting to the main switchboard or a separate instrument panel.

Switchgear Equipments

1. SWITCHES

A switch is a device which is used to open or close an electrical circuit in a convenient way. It can be used under full-load or no-load conditions but it cannot interrupt the fault currents. When the contacts of a switch are opened, an arc is produced in the air between the contacts. This is particularly true for circuits of high voltage and large current capacity. The switches may be classified into (i) air switches (ii) oil switches. The contacts of the former are opened in air and that of the latter are opened in oil.

(I) AIR-BREAK SWITCH

It is an air switch and is designed to open a circuit under load. In order to quench the arc that occurs on opening such a switch, special arcing horns are provided. Arcing horns are pieces of metals between which arc is formed during opening operation. As the switch opens, these horns are spread farther and farther apart. Consequently, the arc is lengthened, cooled and interrupted. Air-break switches are generally used outdoor for circuits of medium capacity such as lines supplying an industrial load from a main transmission line or feeder.

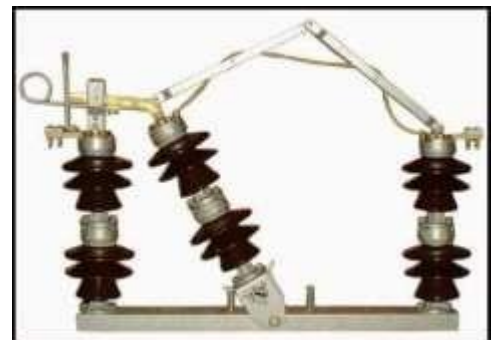

Figure1.1: AIR BREAK SWITCH

(II) ISOLATOR OR DISCONNECTING SWITCH

It is essentially a knife switch and is designed to open a circuit under no load. Its main purpose is to isolate one portion of the circuit from the other and is not intended to be opened while current is flowing in the line. Such switches are generally used on both sides of circuit breakers in order that repairs and replacement of circuit breakers can be made without any danger. They should never be opened until the circuit breaker in the same circuit has been opened and should always be closed



before the circuit breaker is closed.

Figure1.2: ISOLATOR SWITCH

(III) OIL SWITCHES

As the name implies, the contacts of such switches are opened under oil, usually transformer oil. The effect of oil is to cool and quench the arc that tends to form when the circuit is opened. These switches are used for circuits of high voltage and large current carrying capacities

2. FUSES

A fuse is a short piece of wire or thin strip which melts when excessive current flows through it for sufficient time. It is inserted in series with the circuit to be protected. Under normal operating conditions, the fuse element is at a temperature below its melting point. Therefore, it carries the normal load current without overheating. However, when a short circuit or overload occurs, the current through the fuse element increases beyond its rated capacity. This raises the temperature and the fuse element melts (or blows out), disconnecting the circuit protected by it. In this way, a fuse protects the machines and equipment from damage due to excessive currents. It is worthwhile to note that a fuse performs both detection and interruption functions.

3. CIRCUIT BREAKERS

A circuit breaker is an equipment which can open or close a circuit under all conditions viz. no load, full load and fault conditions. It is so designed that it can be operated manually (or by remote control) under normal conditions and automatically under fault conditions.

For the latter operation, a relay circuit is used with a circuit breaker. Figure-1.3 (i) shows the parts of a typical oil circuit breaker whereas Figure-1.3 (ii) shows its control by a relay circuit. The circuit breaker essentially consists of moving and fixed contacts enclosed in strong metal tank and immersed in oil, known as transformer oil.

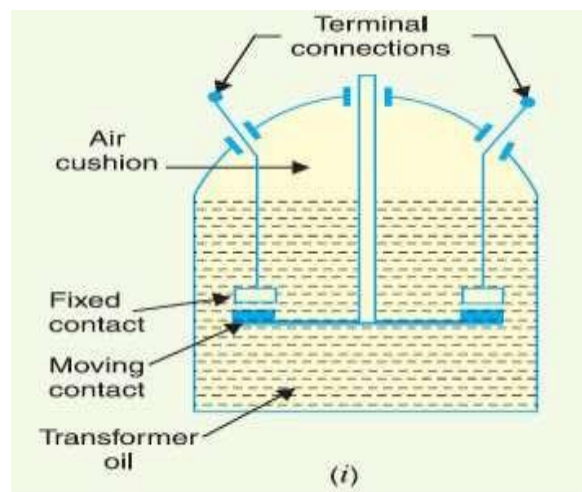

Under normal operating conditions, the contacts remain closed and the circuit breaker carries the full-load current continuously. In this condition, the EMF in the secondary winding of current transformer (CT) is insufficient to operate the trip coil of the breaker but the contacts can be opened (and hence the circuit can be opened) by manual or remote control. When a fault occurs, the resulting overcurrent in the CT primary winding increases the secondary EMF. This energizes the trip coil of the breaker and moving contacts are pulled down, thus

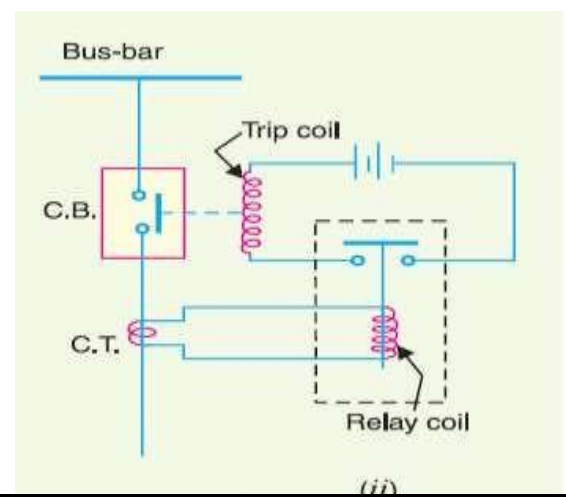

opening the contacts and hence the circuit. The arc produced during the opening operation is quenched by the oil. It is interesting to note that relay performs the function of detecting a fault whereas the circuit breaker does the actual circuit interruption. Figure-1.3

4. RELAYS

A relay is a device which detects the fault and supplies information to the breaker for circuit interruption. Figure-1.3 (ii) shows a typical relay circuit. It can be divided into three parts viz.

(i) The primary winding of a current transformer (CT) which is connected in series with the circuit to be protected. The primary winding often consists of the main conductor itself.

(ii) The second circuit is the secondary winding of CT connected to the relay operating coil.

(iii) The third circuit is the tripping circuit which consists of a source of supply, trip coil of circuit breaker and the relay stationary contacts.

Under normal load conditions, the EMF of the secondary winding of CT is small and the current flowing in the relay operating coil is insufficient to close the relay contacts. This keeps the trip coil of the circuit breaker unenergized. Consequently, the contacts of the circuit breaker remain closed and it carries the normal load current. When a fault occurs, a large current flows through the primary of CT. This increases the secondary EMF and hence the current through the relay operating coil. The relay contacts are closed and the trip coil of the circuit breaker is energized to open the contacts of the circuit breaker.

BUS BAR ARRANGEMENT IN POWER STATION:

When a number of generators or feeders operating at the same voltage have to be directly connected electrically, bus-bars are used as the common electrical component. Bus-bars are copper rods or thin walled tubes and operate at constant voltage. We shall discuss some important Bus Bar Arrangement in Power Station and sub-stations. All the diagrams refer to 3-phase arrangement but are shown in single-phase for simplicity.

1. **Single Bus-bar System:** The single bus-bar system has the simplest design and is used for power stations. It is also used in small outdoor stations having relatively few outgoing or incoming feeders and lines. Fig-1.4 shows the single bus-bar system for a typical power station. The generators, outgoing lines and transformers are connected to the bus-bar. Each generator and feeder is controlled by a circuit breaker. The isolators permit to isolate generators, feeders and circuit breakers from the Bus Bar Arrangement in Power Station for maintenance. The chief advantages of this type of arrangement are low initial cost, less maintenance and simple operation.

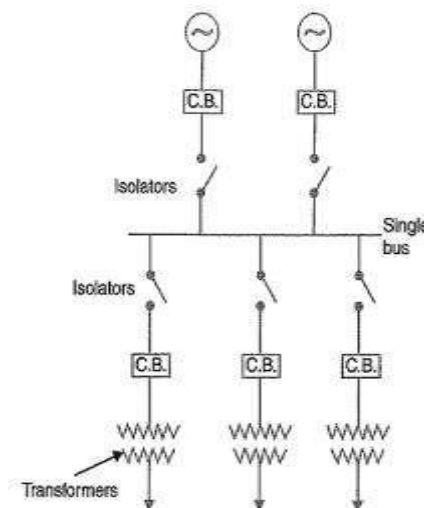

Fig-1.4

Disadvantages:

Single bus-bar system has the following three principal disadvantages :

- The bus-bar cannot be cleaned, repaired or tested without de-energising the whole system.

- If a fault occurs on the bus-bar itself, there is complete interruption of supply.
- Any fault on the system is fed by all the generating capacity, resulting in very large fault

2. Single bus-bar system with Sectionalisation:

In large generating stations where several units are installed, it is a common practice to sectionalise the bus so that fault on any section of the bus-bar will not cause complete shut down. This is illustrated in Fig-1.5 which shows the bus-bar divided into two sections connected by a circuit breaker and isolators. Three principal advantages are claimed for this arrangement. Firstly, if a fault occurs on any section of the bus-bar, that section can be isolated without affecting the supply to other sections. Secondly, if a fault occurs on any feeder, the fault current is much lower than with unsectionalised Bus Bar Arrangement in Power Station. This permits the use of circuit breakers of lower capacity in the feeders. Thirdly, repairs and maintenance of any section of the bus-bar can be carried out by de-energising that section only, eliminating the possibility of complete shut-down.

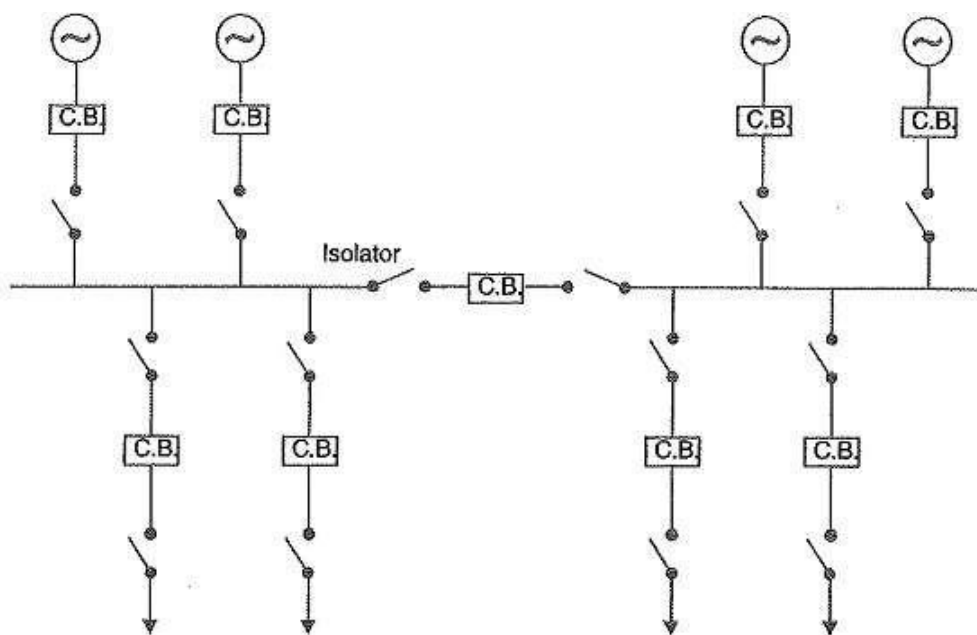

Fig-1.5

It is worthwhile to keep in mind that a circuit breaker should be used as the sectionalising switch so that uncoupling of the bus-bars may be carried out safely during load transfer. Moreover, the circuit breaker itself should be provided with isolators on both sides so that its maintenance can be done while the bus-bars are alive.

3. Duplicate bus-bar system: In large stations, it is important that breakdowns and maintenance should interfere as little as possible with continuity of supply. In order to achieve this objective, duplicate Bus Bar Arrangement in Power Station is used in important stations. Such a system consists of two bus-bars, a “main bus-bar” and a “spare” bus-bar (see Fig-1.6). Each generator and feeder may be connected to either bus-bar with the help of bus coupler which consists of a circuit breaker and isolators. In the scheme shown Main in Fig.1.7, service is interrupted during switch over from one bus to another. However, if it were desired to switch a circuit from one to another

without interruption of service, there would have to be two circuit breakers per circuit. Such an arrangement will be too expensive.

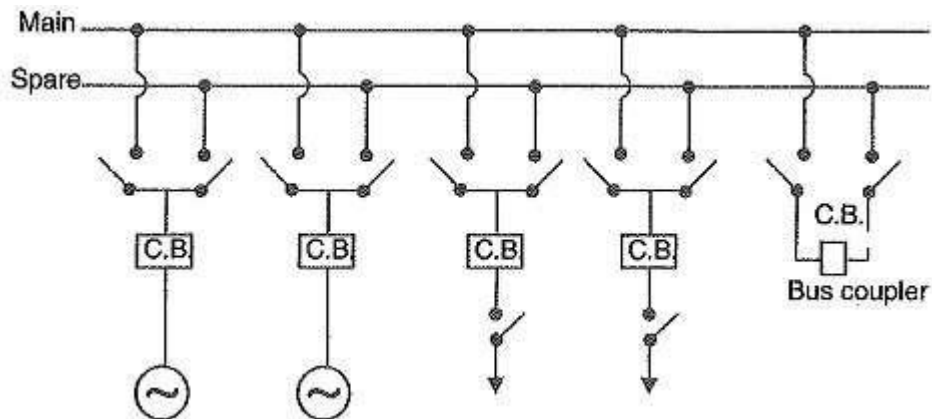

Fig-1.7

Advantages

- If repair and maintenance it to be carried on the main bus, the supply need not be interrupted as the entire load can be transferred to the spare bus.
- The testing of feeder circuit breakers can be done by putting them on spare bus-bar, thus keeping the main bus-bar undisturbed.
- If a fault occurs on the bus-bar, the continuity of supply to the circuit can be maintained by transferring it to the other Bus Bar Arrangement in Power Station.

SWITCHGEAR ACCOMMODATION:

The main components of a switchgear are circuit breakers, switches, bus-bars, instruments and instrument transformers. It is necessary to house the switchgear in power stations and sub-stations in such a way so as to safeguard personnel during operation and maintenance and to ensure that the effects of fault on any section of the gear are confined to a limited region. Depending upon the voltage to be handled, switchgear may be broadly classified into

1. Outdoor type: For voltages beyond 66 kV, switchgear equipment is installed outdoor. It is because for such voltages, the clearances between conductors and the space required for switches, circuit breakers, transformers and others equipment become so great that it is not economical to install all such equipment indoor.
2. Indoor type: For voltages below 66 kV, switchgear is generally installed indoor because of economic considerations. The indoor switchgear is generally of metal-clad type. In this type of construction, all live parts are completely enclosed in an earthed metal casing. The primary object of this practice is the definite localisation and restriction of any fault to its place of origin.

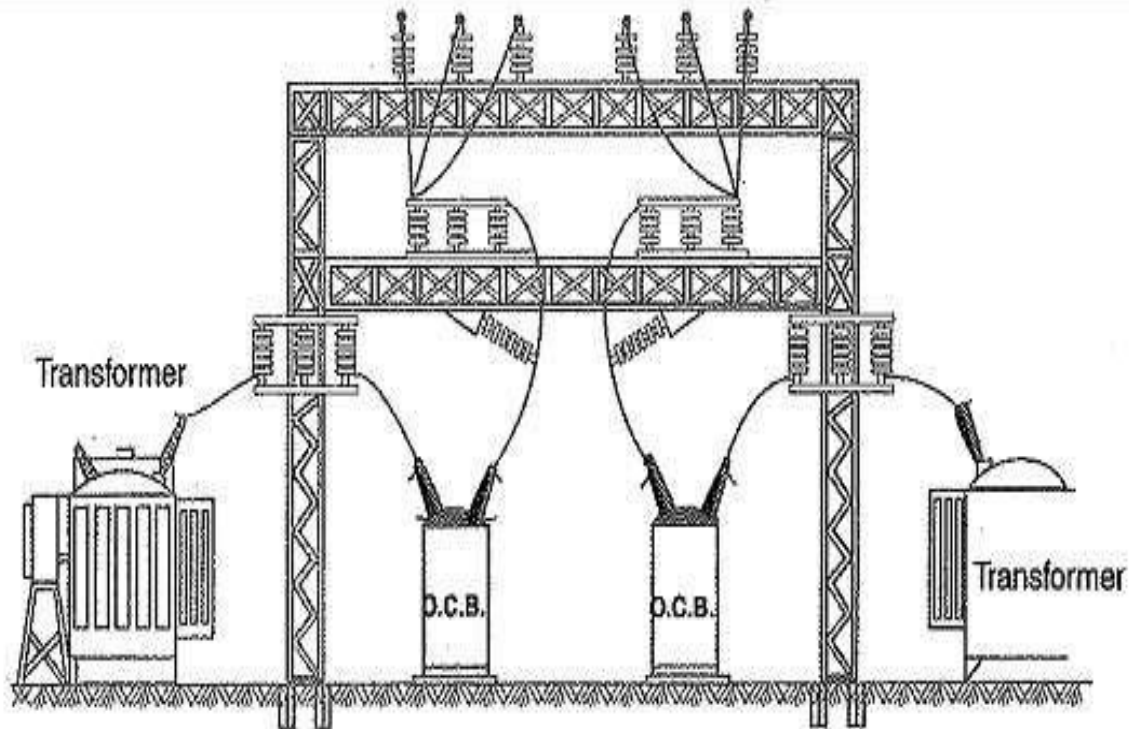

Fig-1.8

Fig-1.8 shows a typical outdoor sub-station with switchgear equipment. The circuit breakers, isolators, transformers and bus-bars occupy considerable space on account of large electrical clearance associated with high voltages.

SHORT CIRCUIT IN POWER SYSTEM:

Whenever a fault occurs on a network such that a large current flows in one or more phases, a Short Circuit in Power System is said to have occurred.

1. Causes of short-circuit: A short circuit in the power system is the result of some kind of abnormal conditions in the system. It may be caused due to internal and/or external effects.

- Internal effects are caused by breakdown of equipment or transmission lines, from deterioration of insulation in a generator, transformer. Such troubles may be due to ageing of insulation, inadequate design or improper installation.
- External effects causing Short Circuit in Power System include insulation failure due to lightning surges, overloading of equipment causing excessive heating; mechanical damage by public etc.

2. Effects of short-circuit: When a short-circuit occurs, the current in the system increases to an abnormally high value while the system voltage decreases to a low value.

- The heavy current due to short-circuit causes excessive heating which may result in fire or Sometimes short-circuit takes the form of an arc and causes considerable damage to the system. For example, an arc on a transmission line not cleared quickly will burn the conductor severely causing it to break, resulting in a long time interruption of the line.
- The low voltage created by the fault has a very harmful effect on the service rendered by the power system. If the voltage remains low for even a few seconds, the consumers' motors may be shut down and generators on the power system may become unstable.

- Due to above detrimental effects of Short Circuit in Power System, it is desirable and necessary to disconnect the faulty section and restore normal voltage and current conditions as quickly as possible.

Short Circuit Currents:

- Most of the failures on the power system lead to short-circuit fault and cause heavy current to flow in the system. The calculations of these short-circuit currents are important for the following reasons :
- A short-circuit on the power system is cleared by a circuit breaker or a fuse. It is necessary, therefore, to know the maximum possible values of short-circuit current so that switchgear of suitable rating may be installed to interrupt them.
- The magnitude of Short Circuit in Power System current determines the setting and sometimes the types and location of protective system.
- The magnitude of short-circuit current determines the size of the protective reactors which must be inserted in the system so that the circuit breaker is able to withstand the fault current.
- The calculation of short-circuit currents enables us to make proper selection of the associated, apparatus (e.g. bus-bars, current transformers etc.) so that they can withstand the forces that arise due to the occurrence of short circuits.

Faults in a Power System:

A fault occurs when two or more conductors that normally operate with a potential difference come in contact with each other. These faults may be caused by sudden failure of a piece of equipment, accidental damage or Short Circuit in Power System to overhead lines or by insulation failure resulting from lightning surges. Irrespective of the causes, the faults in a 3-phase system can be classified into two main categories viz.

(i) Symmetrical faults (ii) Unsymmetrical faults

- Symmetrical faults: That fault which gives rise to symmetrical fault currents (i.e. equal fault currents with 120° displacement) is called a symmetrical fault. The most common example of symmetrical fault is when all the three conductors of a 3-phase line are brought together simultaneously into a short-circuit condition.
- Unsymmetrical faults: Those faults which give rise to unsymmetrical currents (i.e. unequal line currents with unequal displacement) are called unsymmetrical faults. The unsymmetrical faults may take one of the following forms :

(a) Single line-to-ground fault (b) Line-to-line fault (c) Double line-to-ground fault

Chapter II

Symmetrical Fault calculation

SYMMETRICAL FAULTS ON 3 PHASE SYSTEM:

Most of the Symmetrical Faults on 3 Phase System on the power system lead to a short-circuit condition. When such a condition occurs, a heavy current (called short circuit current) flows through the equipment, causing considerable damage to the equipment and interruption of service to the consumers. There is probably no other subject of greater importance to an electrical engineer than the question of determination of short circuit currents under fault conditions. The choice of apparatus and the design and arrangement of practically every equipment in the power system depends upon short-circuit current considerations.

That fault on the power system which gives rise to symmetrical fault currents (i.e. equal fault currents in the lines with 120° displacement) is called a symmetrical fault.

The following points may be particularly noted :

1. The symmetrical fault rarely occurs in practice as majority of the faults are of unsymmetrical nature. However, symmetrical fault calculations are being discussed in this chapter to enable the reader to understand the problems that short circuit conditions present to the power system.
2. The symmetrical fault is the most severe and imposes more heavy duty on the circuit breaker.

Percentage Reactance in Power System:

The Percentage Reactance in Power System of generators, transformers, reactors etc. is usually expressed in percentage reactance to permit rapid short circuit calculations.

The percentage reactance of a circuit is defined as under :

It is the percentage of the total phase-voltage dropped in the circuit when full-load current is flowing.

$$\%X = \frac{I X}{V} \times 100$$

Where I = full-load current V = phase voltage X = reactance in ohms per phase

Alternatively, percentage reactance (%X) can also be expressed in terms of kVA and kV as under :

$$\%X = \frac{(kVA) X}{10 (kV)^2}$$

where X is the reactance in ohms.

If X is the only reactance element in the circuit, then short-circuit current is given by ;

$$I_{sc} = \frac{V}{X}$$

$$= I \times \left(\frac{100}{\%X} \right) \quad (\text{by putting the value of } x)$$

i.e. short circuit current is obtained by multiplying the full-load current by $100 / \% X$.

Percentage Reactance and Base KVA:

It is clear from exp. (ii) above that percentage reactance of an equipment depends upon its kVA rating. Generally, the various equipments used in the power system have different kVA ratings. Therefore, it is necessary to find the Percentage Reactance in Power System of all the elements on a common kVA rating. This common kVA rating is known as base kVA. The value of this base kVA is quite important and may be :

- equal to that of the largest plant
- equal to the total plant capacity
- any arbitrary value

The conversion can be effected by using the following relation :

$$\% \text{ age reactance at base kVA} = \frac{\text{Base kVA}}{\text{Rated kVA}} \times \% \text{ age reactance at rated kVA}$$

Thus, a 1000 kVA transformer with 5% reactance will have a reactance of 10% at 2000 kVA base.

The fact that the value of base kVA does not affect the short circuit current needs illustration. Consider a 3-phase transmission line operating at 66 kV and connected through a 1000 kVA transformer with 5% reactance to a generating station bus-bar. The generator is of 2500 kVA with 10% reactance. The single line diagram of the system is shown in Fig.1. Suppose a short-circuit fault between three phases occurs at the high voltage terminals of transformer. It will be shown that whatever value of base kVA we may choose, the value of short-circuit current will be the same.

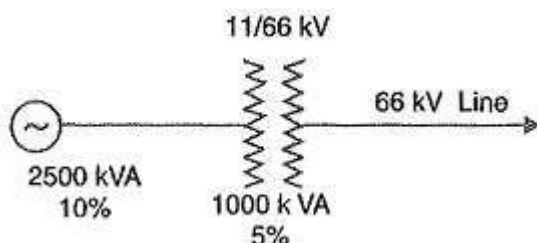

Fig-1

(i) Suppose we choose 2500 kVA as the common base kVA. On this base value, the reactances of the various elements in the system will be :

Reactance of transformer at 2500 kVA base

$$= 5 \times 2500/1000 = 12.5\%$$

Reactance of generator at 2500 kVA base

$$= 10 \times 2500/2500 = 10\%$$

Total percentage reactance on the common base kVA

$$\%X = 12.5 + 10 = 22.5\%$$

The full load current corresponding to 2500 kVA base at 66 kV is given by :

$$I = \frac{2500 \times 1000}{\sqrt{3} \times 66 \times 1000} = 21.87 \text{ A}$$

$$\therefore \text{Short-circuit current, } I_{SC} = I \times \frac{100}{\%X} = 21.87 \times \frac{100}{22.5} = 97.2 \text{ A}$$

(ii) Now, suppose we choose 5000 kVA as the common base value.

Reactance of transformer at 5000 kVA base

$$= 5 \times 5000/1000 = 25\%$$

Reactance of generator at 5000 kVA base

$$= 10 \times 5000/2500 = 20\%$$

Total percentage reactance on the common base kVA

$$\%X = 25 + 20 = 45\%$$

Full-load current corresponding to 5000 kVA at 66 kV is

$$I = \frac{5000 \times 1000}{\sqrt{3} \times 66 \times 1000} = 43.74 \text{ A}$$

$$\text{Short-circuit current, } I_{SC} = I \times \frac{100}{\%X} = 43.74 \times \frac{100}{45} = 97.2 \text{ A}$$

which is the same as in the previous case.

From the above illustration, it is clear that whatever may be the value of base kVA, short-circuit current is the same: However, in the interest of simplicity, numerically convenient value for the base kVA should be chosen.

SHORT CIRCUIT KVA:

Although the potential at the point of fault is zero, it is a normal practice to express the short-circuit current in terms of Short Circuit kVA based on the normal system voltage at the point of fault.

The product of normal system voltage and short-circuit current at the point of fault expressed in kVA is known as Short Circuit kVA.

Let

V = normal phase voltage in volts

I = full-load current in amperes at base kVA

%X = percentage reactance of the system on base kVA upto the fault point

$$\text{Short-circuit current, } I_{SC} = I \left(\frac{100}{\%X} \right)$$

Short-circuit kVA for 3-phase circuit

$$\begin{aligned} &= \frac{3 V I_{SC}}{1000} \\ &= \frac{3 V I}{1000} \times \frac{100}{\%X} \\ &= \text{Base kVA} \times \frac{100}{\%X} \end{aligned}$$

i.e. Short Circuit kVA is obtained by multiplying the base kVA by 100/% X.

Reactor Control of Short-Circuit Currents:

With the fast expanding power system, the fault level (i.e. the power available to flow into a fault) is also rising. The circuit breakers connected in the power system must be capable of dealing with maximum possible short-circuit currents that can occur at their points of connection. Generally, the reactance of the system under fault conditions is low and fault currents may rise to a dangerously high value. In order to limit the short-circuit currents to a value which the circuit breakers can handle, additional reactances known as reactors are connected in series with the system at suitable points. A reactor is a coil of number of turns designed to have a large inductance as compared to its ohmic resistance. The forces on the turns of these reactors under short-circuit conditions are considerable and, therefore, the windings must be solidly braced. It may be added that due to very small resistance of reactors, there is very little change in the efficiency of the system.

Advantages

- Reactors limit the flow of short-circuit current and thus protect the equipment from overheating as well as from failure due to destructive mechanical forces.
- Troubles are localised or isolated at the point where they originate without communicating their disturbing effects to other parts of the power system. This increases the chances of continuity of supply.
- They permit the installation of circuit breakers of lower rating.

LOCATION OF REACTORS IN POWER SYSTEM

1. Generator Reactors:

When reactor is connected between bus bar and generator, it is called a generator reactor. This reactor can also be connected in series with the generator. When a new generator is connected with an old generator, a reactor is added in series with the old generator to provide protection. The value of this reactor depends on the impedance of that generator. Its pu value should be 0.05 or 0.06. See the following figure:

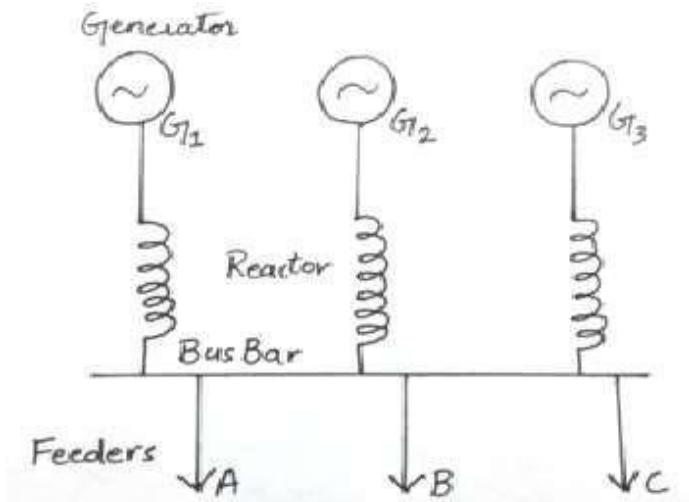

Disadvantages:

1. The fault on a feeder disconnects the supply of other feeders also.
2. After removing the faulty feeder, the generator has to be synchronized again.
3. During normal operation, full load current passes through the reactor which causes continuous power loss.

2. Feeder reactors:

It is when a reactor is connected in series with a feeder as shown in the figure:

Usually short circuits occur on feeders therefore, feeder reactors are very important. In the absence of feeder reactors, if a fault occurs on the nearest generating station, the bus bar voltage will be reduced to zero and the connected generators will lose their synchronism.

Advantages:

1. The voltage drop across a reactor during faulty conditions will not affect the voltage of bus bar, therefore, there are less chances of losing synchronism.
2. A fault on a feeder will not affect any other feeder.

Disadvantages:

1. Every feeder needs a reactor hence the number of reactors increases.
2. If the number of generators increases, then the size of the reactor should also be increased.
3. During normal operation, full load current passes through the reactor which causes continuous power loss.

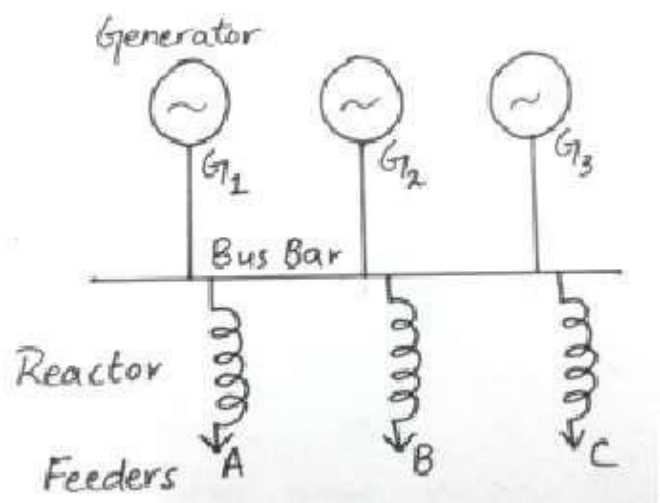

Reactors should be connected according to the power factor of the feeders to regulate proper voltages. Feeder reactance should be about 0.05 to 0.12 pu.

3. Bus bar reactors:

These reactors are connected with bus bars. Bus bar reactors divide the bus bar in smaller sections. If the voltage level is same, no current passes through these reactors and every section act as an independent bus bar.

If a fault occurs on a section of bus bar, the reactor prevents the fault from reaching to other sections and only the fault section is affected. Hence a bus bar should be large enough to protect the system but it should not disturb the synchronism of the system. A reactor which drops the voltage about 30 to 50% at full current is suitable. However the reactance of a single bus bar reactor should be about 0.3 to 0.5 pu.

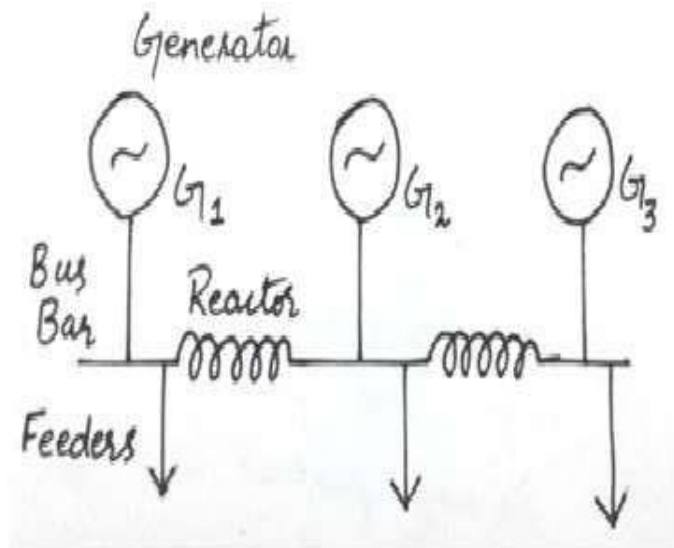

The following methods describe how to decrease the continuous voltage drop and power losses in case of feeder and generator reactors:

1. Ring system:

In this system, a bus bar is divided into different sections and these sections are connected together through a reactor. Each feeder is fed by a separate generator and during normal operation each generator supplies power to its respective load due to which very less power loss occurs in the reactors.

2. Tie bar system:

In this system, the generators are connected to a common bus bar through the reactors and feeders are fed through the generator side of the reactors. This system is very efficient in case of larger systems. The reactance of the reactors in this case is half as compared to the ring system reactance.

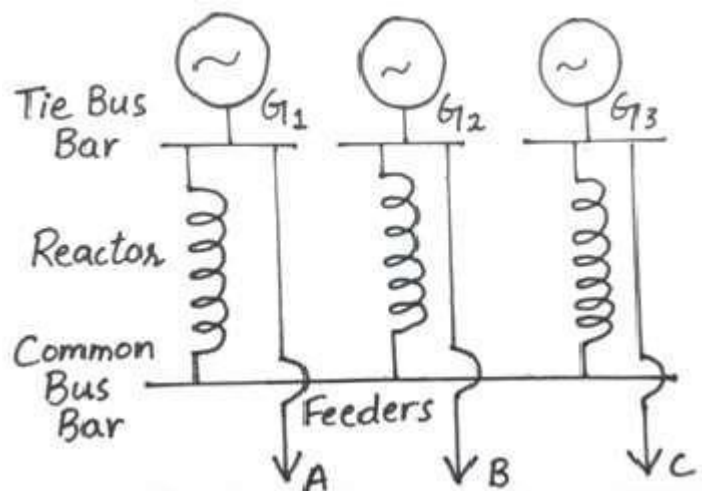

Advantages

This system is more flexible. By increasing the number of sections, the switch gears work efficiently without any modifications in the system.

Disadvantages:

This system is complex and requires an additional bus i.e., tie bar

Chapter III

Fuses

Definition: A fuse is a short piece of metal, inserted in the circuit, which melts when excessive current flows through it and thus breaks the circuit.

The fuse element is generally made of materials having low melting point, high conductivity and least deterioration due to oxidation e.g., silver copper etc. It is inserted in series with the circuit to be protected. Under normal operating conditions, the fuse element is at a temperature below its melting point. Therefore, it carries the normal current without overheating. However, when a short-circuit or overload occurs, the current through the fuse increases beyond its rated value. This raises the temperature and fuse element melts (or blows out), disconnecting the circuit protected by it. In this way, a fuse protects the machines and equipment from damage due to excessive currents.

The time required to blow out the fuse depends upon the magnitude of excessive current. The greater the current, the smaller is the time taken by the fuse to blow out. In other words, a fuse has inverse time-current characteristics as shown in Fig-3.1. Such a characteristic permits its use for over current protection.

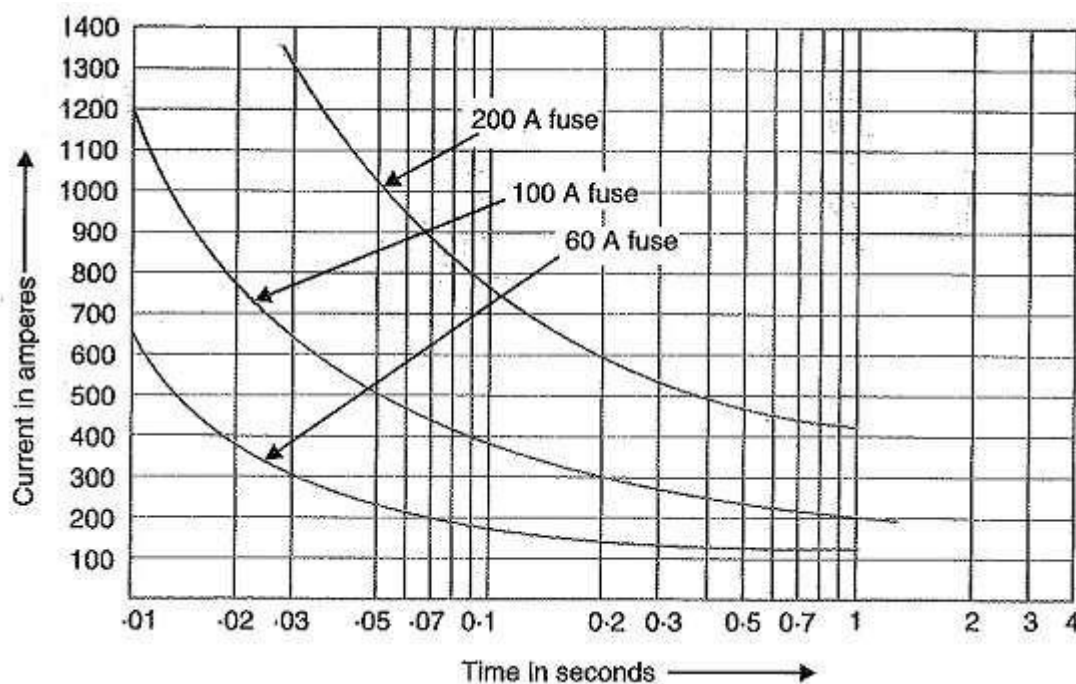

Fig-3.1

Advantages

- It is the cheapest form of protection available.
- It requires no maintenance.
- Its operation is inherently completely automatic unlike a circuit breaker which requires an elaborate equipment for automatic action.
- It can break heavy short-circuit currents without noise or smoke.
- The smaller sizes of fuse element impose a current limiting effect under short-circuit conditions.
- The inverse time-current characteristic of a Fuses Definition makes it suitable for over current protection.
- The minimum time of operation can be made much shorter than with the circuit breakers.

Disadvantages

- Considerable time is lost in rewiring or replacing a fuse after operation.
- On heavy short-circuits, discrimination between fuses in series cannot be obtained unless there is sufficient difference in the sizes of the Fuses Definition concerned.
- The current-time characteristic of a fuse cannot always be co-related with that of the protected apparatus.

Characteristics of Fuse Element:

The function of a fuse is to carry the normal current without overheating but when the current exceeds its normal value, it rapidly heats up to melting point and disconnects the circuit protected by it. In order that it may perform this function satisfactorily, the fuse element should have the following desirable characteristics :

1. low melting point e.g., tin, lead.
2. high conductivity e.g., silver, copper.
3. free from deterioration due to oxidation e.g., silver
4. low cost e.g., lead, tin, copper.

The above discussion reveals that no material possesses all the characteristics. For instance, lead has low melting point but it has high specific resistance and is liable to oxidation. Similarly, copper has high conductivity and low cost but oxidizes rapidly. Therefore, a compromise is made in the selection of material for a Fuses Definition.

Important Terms in Fuses

The following terms are much used in the analysis of fuses :

- Current rating of fuse element: It is the current which the fuse element can normally carry without overheating or It depends upon the temperature rise of the contacts of the fuse holder, fuse material and the surroundings of the Fuses Definition.
- Fusing current: It is the minimum current at which the fuse element melts and thus disconnects the circuit protected by it. Obviously, its value will be more than the current rating of the fuse element.

For a round wire, the approximate relationship between fusing current I and diameter d of the wire is

$$I = k d^{3/2}$$

The fusing current depends upon the various factors such as :

1. material of fuse element
2. length — the smaller the length, the greater the current because a short fuse can easily conduct away all the heat
3. diameter
4. size and location of terminals
5. previous history
6. type of enclosure used

Fusing factor: It is the ratio of minimum fusing current to the current rating of the fuse element i.e.

$$\text{Fusing factor} = \frac{\text{Minimum fusing current}}{\text{Current rating of fuse}}$$

Its value is always more than one. The smaller the fusing factor, the greater is the difficulty in avoiding deterioration due to overheating and oxidation at rated carrying current. For a semi-enclosed or rewirable Fuses Definition which employs copper wire as the fuse element, the fusing factor is usually 2. Lower values of fusing factor can be employed for enclosed type cartridge fuses using silver or bimetallic elements.

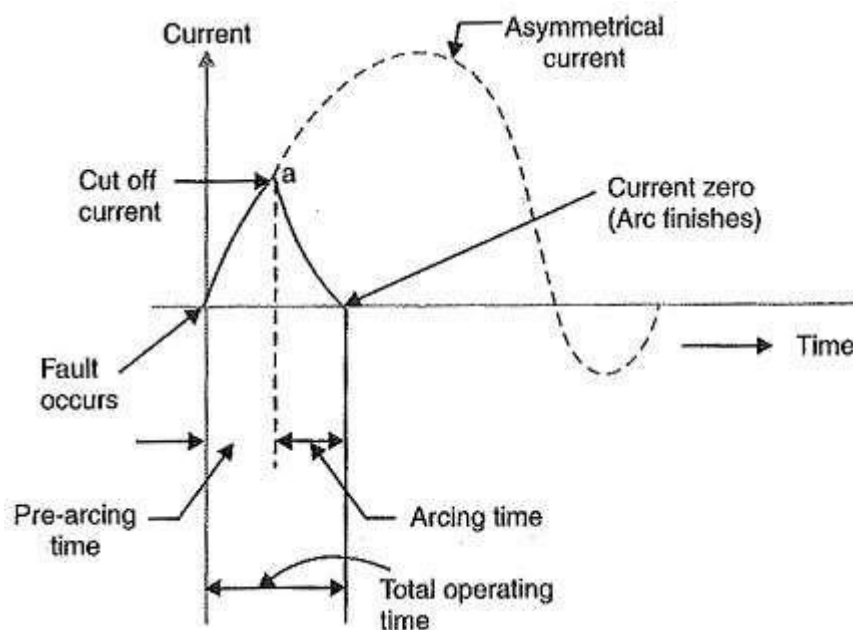

Fig:3.2

Prospective Current: As shown in above fig.3.2 how a.c. current is cut off by a fuse. The fault current would normally have a very large first loop, but it actually generates sufficient energy to melt the fuseable element well before the peak of this first loop is reached. The r.m.s. value of the first loop of fault current is known as prospective current.

Cut-off current: It is the maximum value of fault current actually reached before the fuse melts.

Pre-arcing time: It is the time between the commencement of fault and the instant when cut off occurs.

Arcing time: This is the time between the end of pre-arcing time and the instant when the arc is extinguished.

Total operating time: It is the sum of pre-arcing and arcing times.

Breaking capacity: It is the r.m.s. value of a.c. component of maximum prospective current that a fuse can deal with at rated service voltage.

TYPES OF FUSES:

Fuse is the simplest current interrupting device for protection against excessive currents. Since the invention of first fuse by Edison, several improvements have been made and now-a-days, a variety of Types of Fuses are available. Some fuses also incorporate means for extinguishing the arc that appears when the fuse element melts. In general, Types of Fuses may be classified into :

1. Low voltages fuses

Low voltage fuses can be subdivided into two classes viz.,

a) Semi-enclosed rewirable fuse.

Rewireable fuse (also known as kit-kat type) is used where low values of fault current are to be interrupted. It consists of (i) a base and (ii) a fuse carrier. The base is of porcelain and carries the fixed contacts to which the incoming and outgoing phase wires are connected. The fuse carrier is also of porcelain and holds the Types of Fuses element (tinned copper wire) between its terminals. The fuse carrier can be inserted in or taken out when desired.

When a fault occurs, the fuse element is blown out and the circuit is interrupted. The fuse carrier is taken out and the blown out fuse element is replaced by the new one. The fuse carrier is then re-inserted in the base to restore the supply. This type of fuse has two advantages. Firstly, the detachable fuse carrier permits the replacement of Types of Fuses element without any danger of coming in contact with live parts. Secondly, the cost of replacement is negligible.

Disadvantages

- There is a possibility of renewal by the fuse wire of wrong size or by improper material.
- This type of fuse has a low-breaking capacity and hence cannot be used in circuits of high fault level.
- The fuse element is subjected to deterioration due, to oxidation through the continuous heating up of the element. Therefore, after some time, the current rating of the fuse is decreased e., the fuse operates at a lower current than originally rated.
- The protective capacity of such a Types of Fuses is uncertain as it is affected by the ambient conditions.
- Accurate calibration of the fuse wire is not possible because fusing current very much depends upon the length of the fuse element.

b) High-Rupturing capacity (H.R.C.) cartridge fuse:

The primary objection of low and uncertain breaking capacity of semi-enclosed rewirable fuses is overcome in H.R.C. cartridge fuse. Fig-3.3 shows the essential parts of a typical H.R.C. cartridge fuse. It consists of a heat resisting ceramic body having metal end-caps to which is welded silver current-carrying element. The space within the body surrounding the element is completely packed with a filling powder. The filling material may be chalk, plaster of paris, quartz or marble dust and acts as an arc quenching and cooling medium.

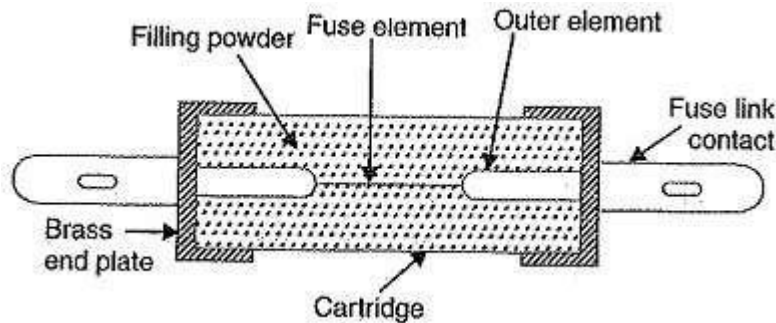

Fig-3.3

Under normal load conditions, the fuse element is at a temperature below its melting point.

Therefore, it carries the normal current without overheating. When a fault occurs, the current increases and the fuse element melts before the fault current reaches its first peak. The heat produced in the process vaporizes the melted silver element. The chemical reaction between the silver vapour and the filling powder results in the formation of a high resistance substance which helps in quenching the arc.

Advantages

- They are capable of clearing high as well as low
- They do not deteriorate with age.
- They have high speed of operation.
- They provide reliable discrimination.
- They require no maintenance.

Disadvantages

- They have to be replaced after each operation.
- Heat produced by the arc may affect the associated switches.
-

2. High Voltage Fuses :

All types of high voltage fuses are used upon the rated voltage up to 1.5 Kv to 138 Kv. High voltage fuses are used to protect the instrument transformers & small transformers. It is made up of silver, copper & tin. When heat generated, the arc produces which causes the boric acid to evolve high amount of gases. That's why these are used in outdoor places.

These are of three types which are as follows:-

a) Cartridge Type HRC Fuses:-

It is similar to low voltage type, only some designing features are different.

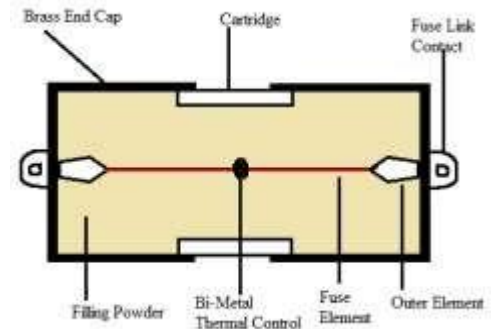

b) Liquid Type HRC Fuses:-

These are used for circuit up to 100A rated current & systems up to 132Kv. These fuses have the glass tube filled with carbon tetrachloride. The one end of the tube is packed and another is fixed by phosphorous bronze wire. When fuse operation starts, the liquid used in the fuse extinguish the arc. This increase the short circuit capacity.

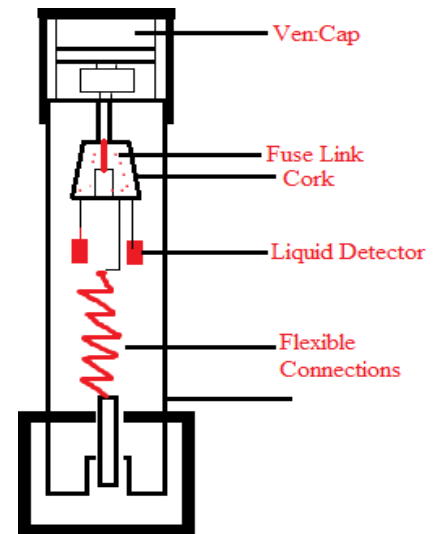

c) Expulsion Type HRC Fuses:- It is the escapable fuse, in which expulsion effect of gases produced by internal arcing. In this, the fuse link chamber is filled with boric acid for expulsion of gases.

d) Metal clad fuses: Metal clad oil-immersed fuses have been developed with the object of providing a substitute for the oil circuit breaker. Such Types of Fuses can be used for very high voltage circuits and operate most satisfactorily under short-circuit conditions approaching their rated capacity.

Chapter IV

Circuit Breaker

INTRODUCTION

Circuit Breakers are quite unique devices in the sense that they are mechanical devices connected to electrical system. Since the time when first electrical systems were utilized, there is always a need for a mechanism or a device that can initiate and interrupt the flow of electric current.

In power system, it is often necessary to switch on or off various electrical devices and circuits like generating plants, transmission line, distribution systems, etc. either in normal operating conditions or under abnormal situations. Originally, this task is performed by a switch and a fuse connected in series with the electrical circuit.

The main disadvantage of such a setup is that if a fuse is blown, it is often time consuming to replace one and restore the power supply. The other and main disadvantage is that a fuse cannot interrupt heavy fault currents.

These limitations restricted the usage of switch and fuse combination to small voltage and small capacity circuits. But in case of high voltage and large current system, a more dependable way than using a switch and fuse is desired.

This is achieved with the help of Circuit Breakers.

What are Circuit Breakers?

Circuit Breakers are mechanical switching devices that can make, carry or break a circuit either manually or automatically under normal and abnormal circuit conditions. Under normal conditions, a circuit breaker can make, carry or break currents and under abnormal conditions, it can make or carry for a specific time and break the currents.

The characteristics of a Circuit Breaker are as follows:

- It can make or break a circuit under normal operating conditions either manually or using a remote control.
- Under abnormal or fault conditions, it can break the circuit automatically.
- It can make the circuit under fault conditions either manually or using a remote control.

These characteristics of a Circuit Breaker makes it a very useful device for switching and protection in a power system.

Principle of Operation of Circuit Breakers

The main duty of a Circuit Breaker is to switch ON and OFF the electrical circuits during normal or abnormal operating conditions, once or several times repeatedly. The operating principle of a circuit breaker is very simple.

A typical circuit breaker consists of a fixed and a moving contact called Electrodes. These contacts are closed under normal circuit operating conditions.

If the system becomes faulty, the contacts will open automatically and alternatively, these contacts can also be opened manually whenever desired (for example, during maintenance).

Under faulty system conditions, a simple mechanism will pull the moving contacts away as a result of trip coil getting energized and essentially opening the circuit.

An important phenomenon that occurs during the opening of the contacts is the Arc Phenomenon. If a fault is detected on any part of the system, the contacts of the circuit breaker are separated and during this process, an arc is struck between them. Until the arc discharges, the current in the circuit continues to flow.

The arc not only delays the circuit interruption but also produces a significant amount of heat that could potentially damage the circuit breaker itself or the entire system. Hence, one of the main challenges in circuit breakers is to extinguish the arc as quickly as possible.

Arc Phenomenon in Circuit Breakers

During faulty conditions like a short circuit, for example, a significantly large amount of current flows through the contacts of the circuit breaker before the protective mechanism kicks in and opens the contacts.

The instant when the contacts start to open, the contact area is suddenly reduced and the current density increases due to the large short circuit current. This leads to a rise in temperature and the heat produced is sufficient to ionize the medium (air or oil). The ionized medium acts as a conductor and an arc is struck between the contacts.

This arc provides a low resistance path between the contacts (even though they are open) and the large faulty current continues to flow as long as the arc exists and it defeats the purpose of the circuit breaker.

Reasons for Arc

Before understanding the methods to extinguish arcs, let us try to analyze the factors responsible for the maintaining the arc between the contacts of the circuit breaker.

The reasons can be confined to the following two:

- Potential Difference between the contacts
- Ionized particles between the contacts

The potential difference between the contacts is sufficient for the arc to exist as the separation between the contacts is less. Also, the ionized medium i.e. ionized air or oil have a tendency to maintain the arc.

Different Methods of Arc Extinction

Basically, there are two ways in which you can extinguish the arc between the contacts of a circuit breaker. They are:

a) High Resistance Method:

In the High Resistance method, the resistance of the arc is increased so that the current will become insignificant to maintain the arc. There are several ways in which you can implement the High Resistance Method.

Some ways to increase the resistance of the arc are:

- Increasing the arc length
- Cooling the arc
- Reducing the area of cross section of the arc
- Splitting the arc

This method is usually implemented in DC Circuit breakers and Low Capacity AC Circuits as it produces enormous amount of heat during the arc extinction.

b) Low Resistance Method :

In the low resistance method, as the name suggests, the resistance of the arc maintained low until the current becomes zero and the arc extinguishes naturally. Hence, this method is also known as Current Zero Method.

The low resistance method is often implemented in high power AC circuit breakers as this method prevents restriking of the arc even when the voltage across the contacts rises.

Another important factor to consider is the ionization of the medium and the tendency of ionized particles to maintain the arc. If the medium between the contacts is deionized, as quickly as possible, the possibility of restriking can be reduced significantly.

Deionization of the medium can be achieved by the following ways:

- Increasing the gap between the contacts
- Increasing the pressure
- Cooling the arc
- Gas Blast effect

CLASSIFICATION OF CIRCUIT BREAKERS

There are several ways of classifying different circuit breakers. Some of the common criteria used for classification of circuit breakers are:

- Intended Voltage Applications
- Location of the installation
- Design Characteristics
- Method and medium used for current interruption (Arc Extinction)

Even though there are several ways to classify circuit breakers, the classification based on the medium and method of current interruption is most general and significant in the industry as well. For now, we will briefly about all these classifications and in the later sections, we will discuss the main classification (i.e. based on method of arc extinction) more thoroughly.

Based on Voltage Class

The first logical classification of circuit breakers is based on the operating voltage intended for the circuit breakers to be used. There are two types of circuit breakers based on the voltage level. They are:

- Low Voltage Circuit Breakers, which are intended to be used at voltages up to 1000V.
- High Voltage Circuit Breakers, which are intended to be used at voltages greater than 1000V.

Again, high voltage circuit breakers are further divided into 123kV or above and 72.5kV or below.

Based on Type of Installation

Circuit breakers are also classified based on the location of installation i.e. outdoor or indoor installation. These circuit breakers are usually high voltage circuit breakers. Indoor circuit breakers are designed to be used inside buildings or with special weather resistant enclosures, usually a metal clad switchgear enclosure.

In fact, the main difference between indoor and outdoor circuit breakers is the packaging structures and enclosures while the internal structure like current carrying parts, interrupting mechanism and operation are pretty much the same.

Based on Type of External Design

The classification of circuit breakers is also done based on the physical structural design and it is usually done in two ways. They are:

- Dead Tank Type Circuit Breakers
- Live Tank Type Circuit Breakers

In Dead Tank Type Circuit Breakers, the switching device is placed in a vessel at ground potential and it is surrounded by interrupters and insulating medium. On the other hand, in a Live Tank Type Circuit Breaker, the vessel containing the interrupters and insulating medium is at higher potential than ground.

Dead Tank Circuit Breakers are more common in the US while Live Tank Circuit Breakers are frequently used in Europe and Asia.

Based on Type of Interrupting Medium

The most significant and important classification of circuit breakers is based on the interrupting medium and arc extinction method. In fact, the current interrupting medium and the arc extinction method have become the main factors in designing the circuit breakers and also, they dictated the overall design parameters.

Originally, oil and air served as the interrupting medium and continue to be still used even after almost a century since their first implementation.

There are two newer techniques, one involving vacuum and the other one based on Sulfurhexafluoride (SF_6) gas as the interrupting medium. These two dominate today's circuit breaker industry but oil and air circuit breakers are also still in service.

DIFFERENT TYPES OF CIRCUIT BREAKERS

Since the general and most common way of classification of circuit breakers is based on medium used for arc extinction, we will see different types of circuit breakers based on the same.

Usually, the medium used for extinction of arc is air, oil, Sulfurhexafluoride gas or vacuum. Hence, the different types of circuit breakers based on these media are:

a) Air Magnetic Circuit Breakers

The first circuit breaker is the Air Magnetic Circuit Breaker. It is also called as Arc Chute Circuit Breaker. Usually, it consists of a number of plates between the contacts and are made up of either metallic or insulated materials.

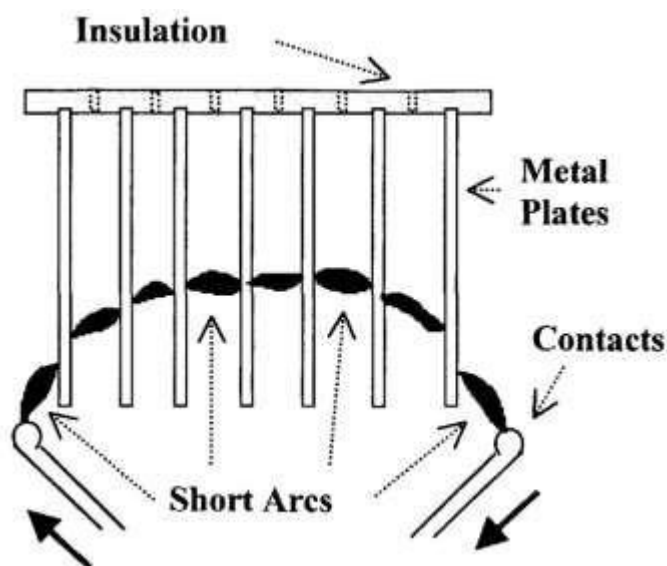

Fig:4.1

When the arc is struck, it comes in contact with the series of metal plates. As a result, the main arc is divided into a number of smaller arcs that cross the plates and the voltage drop is usually 30 to 40 volts. In this type of circuit breaker, the plates are usually metallic.

Another type of arc chute circuit breaker is based on a magnetic low-out assist. This type usually uses insulated arcing plates and are made of ceramic.

In this type, the arc is first made to travel between the insulating plates to elongate the arc. Then the arc is cooled by diffusion. When the circuit breaker begins to open and the arc is initiated, the separation between the contacts is increased. A coil, which is not part of the main conducting circuit, comes into contact with the current.

The magnetic field created by this coil will exert a force on the arc and as a result, the arc tends to move deeper into the chute.

b) Air Blast Circuit Breakers

The second 'air' based circuit breakers are air blast circuit breakers. In this type, a high-pressure air-blast is used as arc extinguishing medium. In case of a fault, the air-blast, controlled by a blast valve, will open the contacts and also cools the arc.

The arc and the arcing products are swept into the atmosphere, which rapidly increases the dielectric strength of the medium. As a result, the restriking of arc is prevented. The arc is extinguished consequently and the flow of current is completely interrupted.

There are three types of air blast circuit breakers based on the direction of the air-blast in relation to the arc. They are:

- Axial Blast Type
- Cross Blast Type
- Radial Blast Type

In axial-blast circuit breakers, the air-blast flows in the same direction as the arc. The high-pressure air-blast will push the moving contact away, opening the circuit and also pushes the arc along with it.

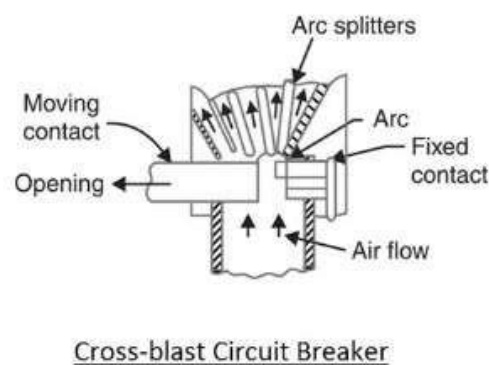
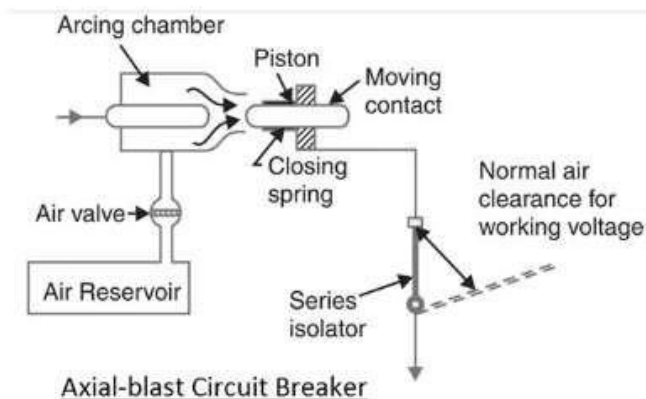

The air-blast in cross-blast type circuit breakers is perpendicular to the arc path and in radial-blast type circuit breakers, it is directed radially.

Advantage

- Risk of fire is eliminated.
- Arcing products are completely removed by the air-blast.
- Significantly faster increase in dielectric strength. Hence, the contact gap can be less, resulting in smaller device.
- Arcing time is very small and the arc energy is also small. Suitable for frequent operations.
- Air-blast is independent to the interrupting current.

Disadvantages

- Arc extinguishing properties of air are inferior.
- Sensitive to variations in restricting voltage.
- Air-blast compressor needs to be maintained.

c) Oil Circuit Breakers

In Oil Circuit Breakers, an insulating oil is used as the arc extinguishing medium. As the contacts are opened in oil, when the arc strikes, the surrounding oil is evaporated as hydrogen gas.

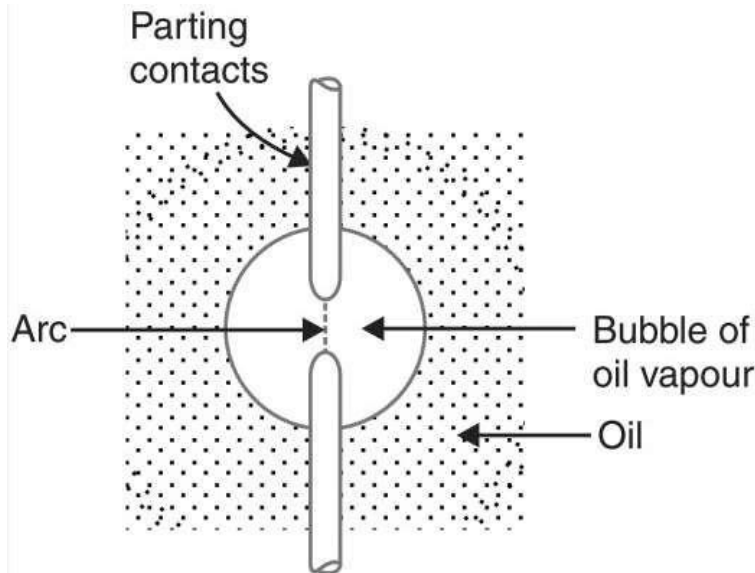

Fig-4.2

The hydrogen gas bubble will surround the arc region. Hydrogen gas, due to its high thermal conductivity, cools the arc and also deionizes the medium. Also, the gas causes turbulence in the surrounding oil and all the arcing products are pushed away from the arc.

There are two types of oil circuit breakers. They are:

- Bulk Oil Circuit Breakers
- Low Oil Circuit Breakers

As the name suggests, bulk oil circuit breakers use a significantly large quantity of oil. Further, bulk oil circuit breakers are again divided into two types.

- Plain Break Oil Circuit Breakers
- Arc Control Oil Circuit Breakers

In Plain Break Oil Circuit Breakers, the contacts are separated in the oil tank and the system for arc control is to increase the separation of the contacts. When a critical gap between the contacts is reached, the arc extinction occurs.

The lack of control over the arc in plain break oil circuit breakers is overcome in Arc Control Oil Circuit Breakers. The arc control is implemented in two ways known as:

- Self-blast Oil Circuit Breakers
- Forced-blast Oil Circuit Breakers

In self-blast type breakers, an insulating rigid pressure chamber is used with the contacts and the gases released during arcing are confined to this chamber or pot. The high pressure developed in the small chamber will force the oil as gas to go through the arc and subsequently extinguishing it.

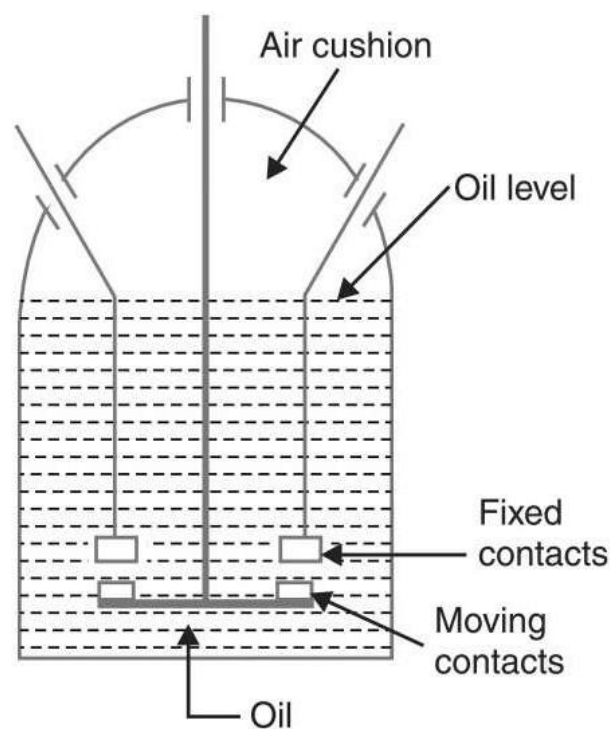

Fig-4.3

There are three type or designs of pressure pots in Self-blast Oil Circuit Breakers. They are:

- Plain Explosion Pot
- Cross Jet Explosion Pot
- Self-compensated Explosion Pot

Coming to Forced-blast Oil Circuit Breakers, a piston cylinder is used to create the necessary oil pressure in contrast to Self-blast Oil Circuit Breakers, where the pressure is developed by the arc itself.

In all the Bulk Oil Circuit Breakers mentioned above, the oil has two jobs. One is to act as an arc extinguishing medium and the other is to insulate live circuit from earth. Only a small percentage (10% or less) is actually used for arc extinction and the majority of the oil is used for insulating purpose.

In Low Oil Circuit Breakers, oil is used for arc extinction and a solid material like porcelain and paper are used for insulation.

Advantages

- Oil has excellent cooling property and the arc energy converts the oil into gas.
- Acts as insulator between live wires and earth.

Disadvantages

- Oil is inflammable and is a fire hazard.
- Arcing products cannot escape and remain in the oil.

d) Sulfurhexafluoride (SF₆) Circuit Breakers

In Sulfur Hexafluoride circuit breakers, Sulfur Hexafluoride with chemical formula SF₆, is used as the arc extinguishing medium.

The Sulfurhexafluoride gas is electro-negative in nature i.e. it attracts free electrons. When the circuit contacts are opened, a high pressure Sulfurhexafluoride gas flows through the chamber as the arc strikes.

Free electrons produced during the arcing are quickly absorbed by the SF₆ gas resulting in immobile negative ions. As the arc loses its conducting electrons, the insulating strength of the surrounding medium is quickly increased and the arc completely extinguishes.

Following image shows a simplified construction of SF₆ Circuit Breaker. Both the fixed and moving contacts are placed in arc chamber, which contains Sulfurhexafluoride gas. When the contacts open, a high pressure SF₆ gas from a reservoir will flow through the chamber's inlet.

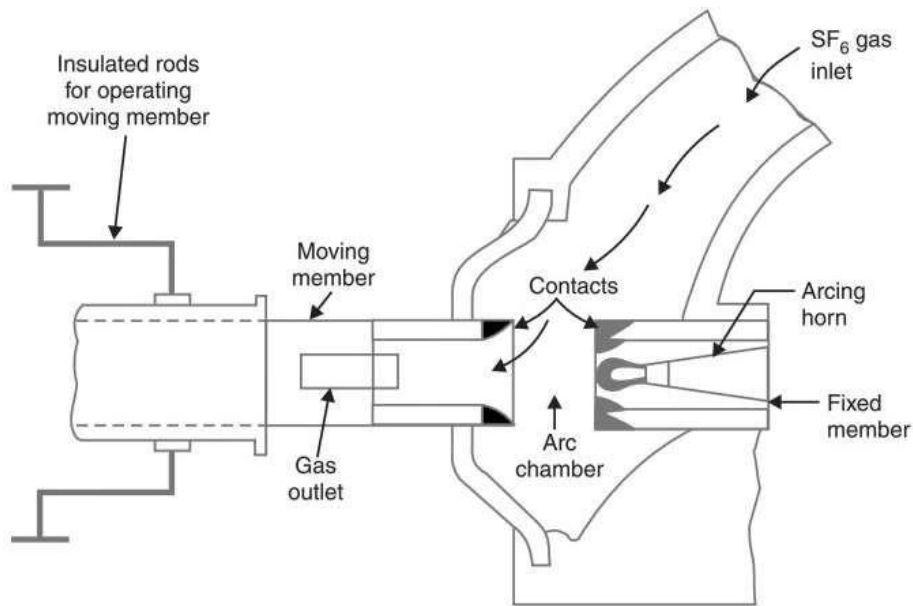

Fig-4.4

Advantages

- Superior arc extinguishing property.
- Can interrupt larger currents as the dielectric strength of SF₆ gas is almost 3 times greater than air.
- Noise free operation and no exhaust into atmosphere.
- Moisture free operation as the gas filled chamber keeps in interior dry.
- Very low maintenance and requires minimum equipment.
- Suitable for hazardous and hostile conditions like coal mines as the breakers are enclosed and sealed.

Disadvantages

- Sulfurhexafluoride gas is very costly.
- SF₆ has to be reconditioned after every operation.
- This high pressure Sulfurhexafluoride gas will absorb all the conducting free electrons and as a result causes the extinction of the arc.

e) Vacuum Circuit Breakers

In vacuum circuit breakers or VCB, the arc extinguishing medium is, well Vacuum. It offers superior arc extinguishing properties than other medium as it has the highest insulating strength.

When the contacts of the circuit breaker in vacuum are opened, an arc is formed due to ionization of the metal vapours of the contacts. But the arc is quickly extinguished as the vapours rapidly condense.

A typical vacuum circuit breaker is shown in the following image. It consists of a moving contact and a fixed contact and also an arc shield mounted in a vacuum chamber. The outer insulating body is usually made up of glass or ceramic.

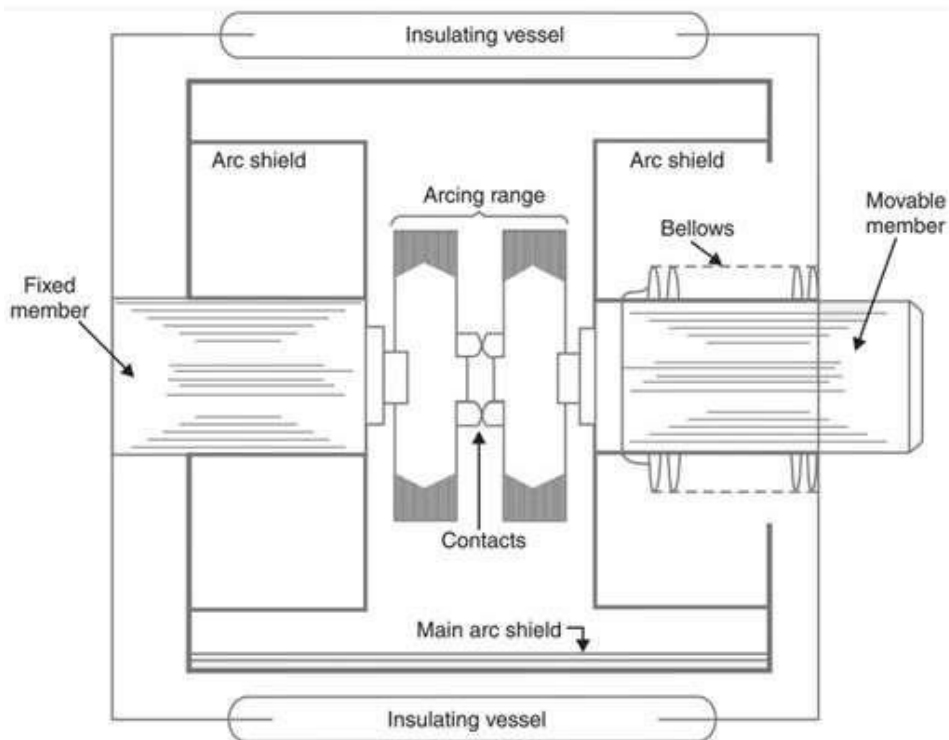

Fig-4.5

Advantages

- No fire hazards.
- Compact, very reliable and have very long life.
- No gas is generated during or after operation.
- No or very little maintenance.
- VCB can interrupt any fault current.
- Can withstand lightning strikes.
- Low arc energy is released.

Chapter V

Protective Relays

A Protective Relay is a device that detects the fault and initiates the operation of the circuit breaker to isolate the defective element from the rest of the system.

The Protective Relay detect the abnormal conditions in the electrical circuits by constantly measuring the electrical quantities which are different under normal and fault conditions. The electrical quantities which may change under fault conditions are voltage, current, frequency and phase angle. Through the changes in one or more of these quantities, the faults signal their presence, type and location to the protective relay. Having detected the fault, the relay operates to close the trip circuit of the breaker. This results in the opening of the breaker and disconnection of the faulty circuit.

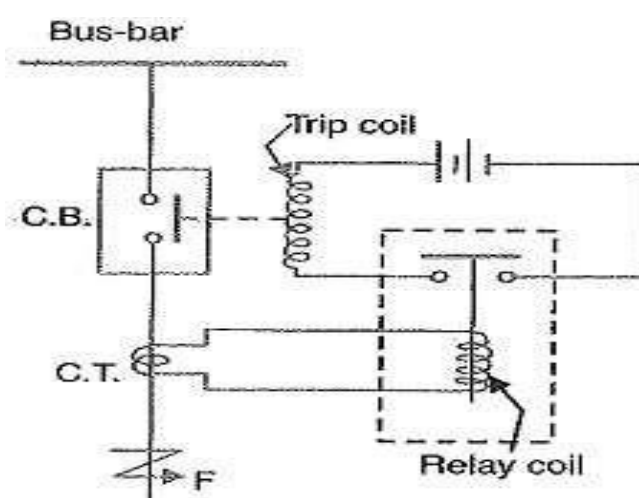

Fig-5.1

A typical relay circuit is shown in Fig-5.1 This diagram shows one phase of 3-phase system for simplicity. The relay circuit connections can be divided into three parts viz.

- First part is the primary winding of a current transformer (CT.) which is connected in series with the line to be protected.
- Second part consists of secondary winding of C.T. and Cu. the relay operating coil.
- Third part is the tripping circuit which may be either a.c. or d.c. It consists of a source of supply, the trip coil of the circuit breaker and the relay stationary contacts.

When a short circuit occurs at point F on the transmission line, the current flowing in the line increases to an enormous value. This results in a heavy current flow through the relay coil, causing the relay to operate by closing its contacts. This in turn closes the trip circuit of the breaker, making the circuit breaker open and isolating the faulty section from the rest of the system. In this way, the relay ensures the safety of the circuit equipment from damage and normal working of the healthy portion of the system.

FUNDAMENTAL REQUIREMENTS OF PROTECTIVE RELAY:

The principal function of Protective Relay is to cause the prompt removal from service of any element of the power system when it starts to operate in an abnormal manner or interfere with the effective operation of the rest of the system. In order that protective relay system may perform this function satisfactorily, it should have the following qualities :

1. Selectivity:

It is the ability of the protective system to select correctly that part of the system in trouble and disconnect the faulty part without disturbing the rest of the system.

A well designed and efficient relay system should be selective i.e. it should be able to detect the point at which the fault occurs and cause the opening of the circuit breakers closest to the fault with minimum or no damage to the system. This can be illustrated by referring to the single line diagram of a portion of a typical power system shown in Fig-5.2. It may be seen that circuit breakers are located in the connections to each power system element in order to make it possible to disconnect only the faulty section. Thus, if a fault occurs at bus-bars on the last zone, then only breakers nearest to the fault viz. 10, 11, 12 and 13 should open. In fact, opening of any other breaker to clear the fault will lead to a greater part of the system being disconnected.

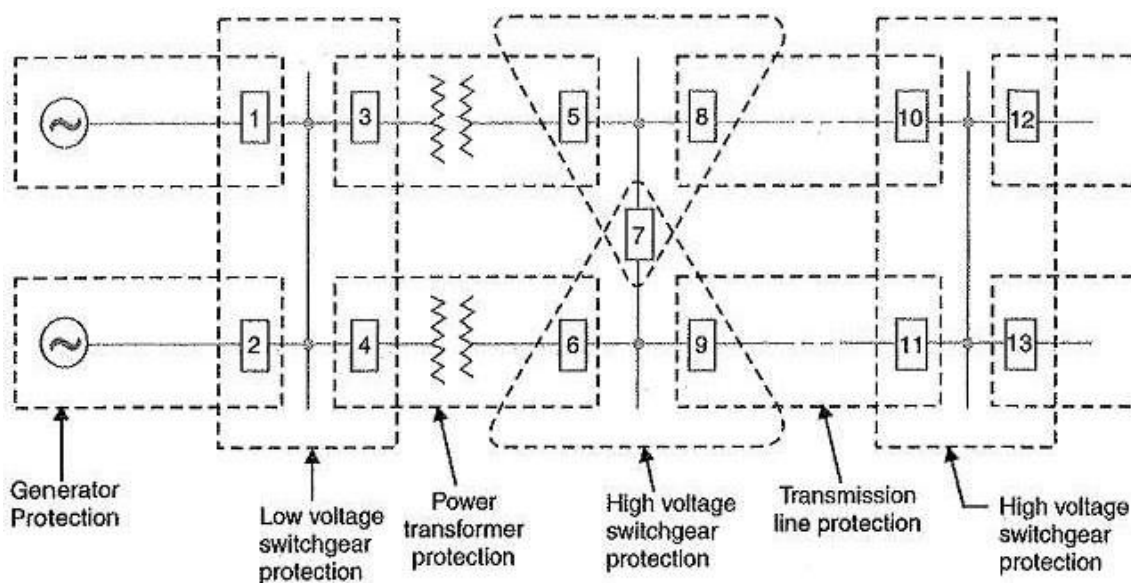

Fig-5.2

In order to provide selectivity to the system, it is a usual practice to divide the entire system into several protection zones. When a fault occurs in a given zone, then only the circuit breakers within that zone will be opened. This will isolate only the faulty circuit or apparatus, leaving the healthy circuits intact.

The system can be divided into the following protection zones :

- Generators
- Low-tension switchgear
- Transformers
- High-tension switchgear
- Transmission lines

It may be seen in Fig that there is certain amount of overlap between the adjacent protection zones. For a failure within the region where two adjacent zones overlap, more breakers will be opened than the minimum necessary to disconnect the faulty section. But if there were no overlap, a failure in the region between zones would not lie in either region and, therefore, no breaker would be opened. For this reason, a certain amount of overlap is provided between the adjacent zones.

2. Speed:

The relay system should disconnect the faulty section as fast as possible for the following reasons

- Electrical apparatus may be damaged if they are made to carry the fault currents for a long time.
- A failure on the system leads to a great reduction in the system voltage. If the faulty section is not disconnected quickly, then the low voltage created by the fault may shut down consumers motors and the generators on the system may become unstable.
- The high speed relay system decreases the possibility of development of one type of fault into the other more severe type.

3. Sensitivity:

It is the ability of the relay system to operate with low value of actuating quantity.

Sensitivity of a relay is a function of the volt-amperes input to the coil of the relay necessary to cause its operation. The smaller the volt-ampere input required to cause relay operation, the more sensitive is the relay. Thus, a 1 VA relay is more sensitive than a 3 VA relay. It is desirable that relay system should be sensitive so that it operates with low values of volt-ampere input.

4. Reliability:

It is the ability of the Protective Relay system to operate under the pre-determined conditions. Without reliability, the protection would be rendered largely ineffective and could even become a liability.

5. Simplicity:

The relaying system should be simple so that it can be easily maintained. Reliability is closely related to simplicity. The simpler the protection scheme, the greater will be its reliability.

6. Economy:

The most important factor in the choice of a particular protection scheme is the economic aspect. Sometimes it is economically unjustified to use an ideal scheme of protection and a compromise method has to be adopted. As a rule, the protective gear should not cost more than 5% of total cost. However, when the apparatus to be protected is of utmost importance (e.g. generator, main transmission line etc.), economic considerations are often subordinated to reliability.

ELECTROMECHANICAL RELAYS

These relays are constructed with electrical, magnetic & mechanical components & have an operating coil & various contacts, & are very robust & reliable. Based on the construction, characteristics, these are classified in three groups. *Attraction relays* Attraction relays can be AC & DC and operate by the movement of a piece of iron when it is attracted by the magnetic field produced by a coil.

There are two main types of relays:

1. Attracted armature relays

- Consists of a bar or plate (made of iron) that pivots when it is attracted towards the coil.
- The armature carries the moving part of the contact, which is closed or opened, according to the design, when the armature is attracted to the coil.

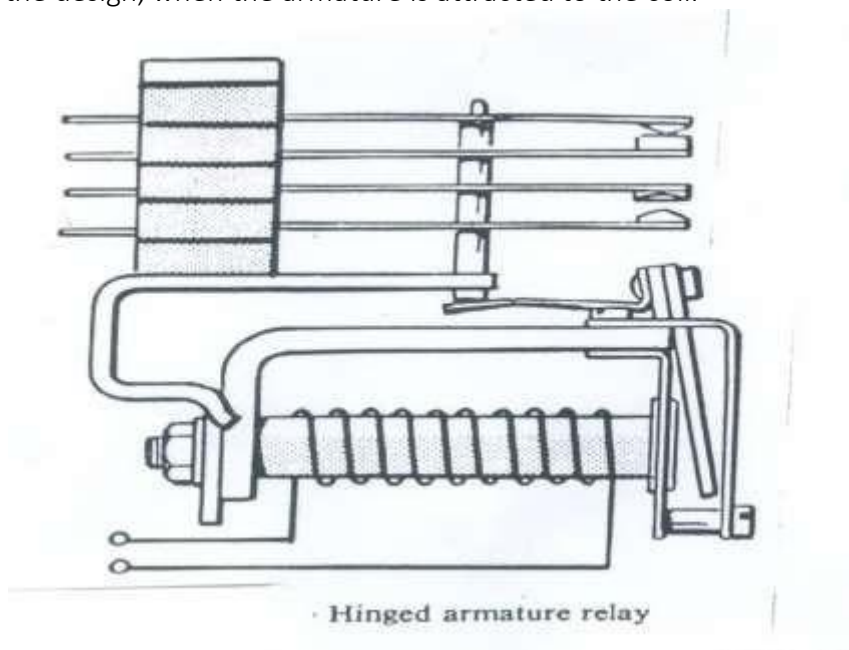

Fig-5.3

- *Solenoid type relays* In this a plunger or a piston is attracted axially within the field of the solenoid. In this case, the piston carries the moving contacts.

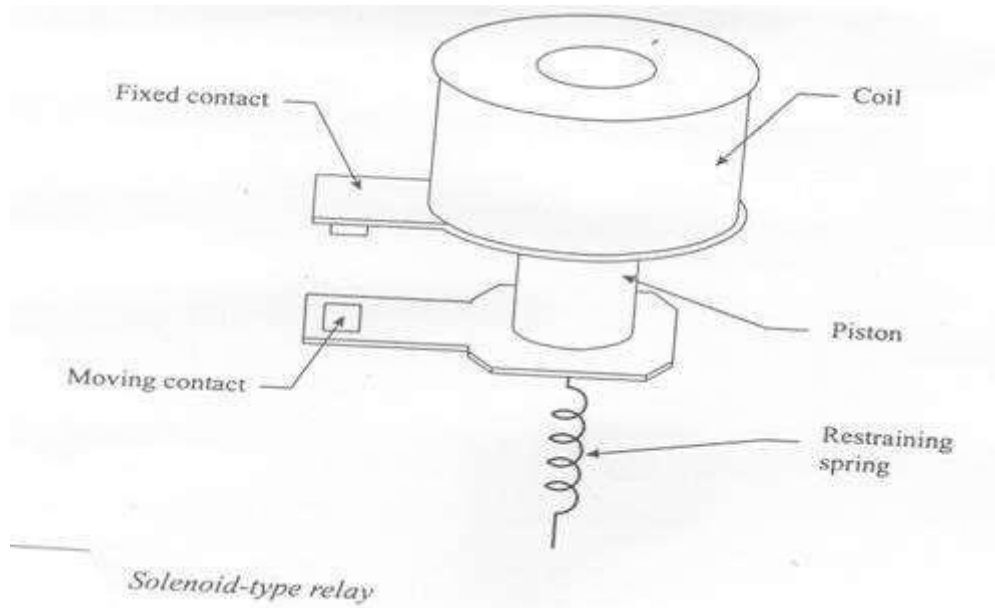

Fig-5.4

The force of attraction = $K_1 I^2 - K_2$

Where, K_1 depends on

- The number of turns of the coil
- The air gap
- The effective area
- The reluctance of the magnetic circuit

K_2 is the restraining force, usually produced by spring. For threshold or balanced condition, the resultant force is zero.

$$K_1 I^2 = K_2 \quad I = \sqrt{\left(\frac{K_1}{K_2}\right)}$$

In order to control the value of current at which relay operates, the parameters K_1 and K_2 may be adjusted. Attraction relays effectively have no time delay and are widely used when instantaneous operation is required.

Relays with movable coils

This type of relay consists of a rotating movement with a small coil suspended or pivoted with the freedom to rotate between the poles of a permanent magnet. The coil is restrained by two special springs which also serve as connections to carry the current to the coil.

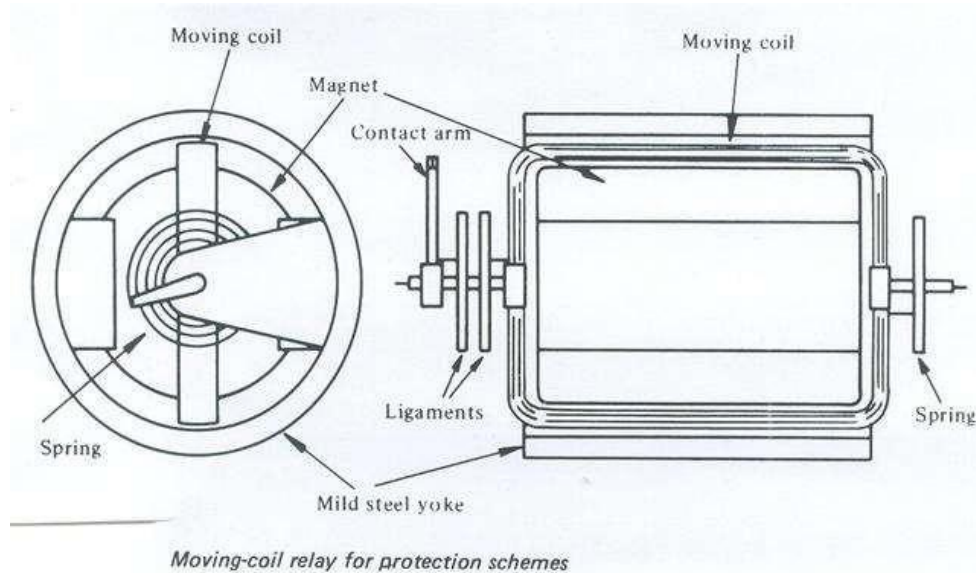

Fig-5.5

The torque produced in the coil is $T = B i a N$. Where, T = Torque B = flux density l = length of the coil a = distance between the two sides of the coil i = current flowing through the coil N = number of turns in the coil

The relay has inverse type characteristic

Induction relays

- An induction relay works only with AC
- It consists of an electromagnetic system Which operates on a moving conductor, generally in the form of a DISC or CUP

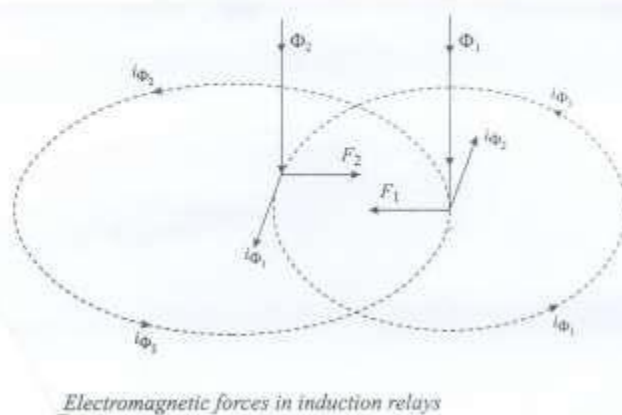

Fig-5.6

Various quantities are shown at instant when

- Both fluxes are directed downward
- Are increasing in magnitude

Let

$$\phi_1(t) = \phi_{m1} \sin(\omega t)$$

$$\phi_2(t) = \phi_{m2} \sin(\omega t + \theta)$$

It may be assumed with negligible error that the paths in which rotor current flow have negligible self inductance.

$$F = F_2 - F_1$$

$$= \alpha \phi_2(t) i_{\phi_1}(t) - \phi_1(t) i_{\phi_2}(t)$$

$$= \alpha \phi_{m1} \phi_{m2} [\sin(\omega t + \theta) \cos(\omega t) - \sin(\omega t) \cos(\omega t + \theta)]$$

$$= \alpha \phi_{m1} \phi_{m2} \sin \theta$$

Since sinusoidal flux waves are assumed, we may substitute the rms values of the fluxes for the crest values in the above equation.

$$F \propto \phi_{m1} \phi_{m2} \sin \theta$$

- It may be noted that the net force is same at every instant.
- The net force is directed from the point where the leading flux pierces the rotor towards the point where the lagging flux pierces the rotor.
- Actuating force is produced in the presence of out of phase fluxes.
- Maximum force is produced when $\theta = 90^\circ$

Classification of induction relays 1. Shaded pole relay 2. Watthour- meter type relay 3. Cup type relay
The air gap flux produced by the current flowing in a single coil is split into two out of phase components by a so called „Shading Ring“ generally of copper, that encircles part of the pole face of each pole at the air gap.

- The shading ring may be replaced by coils if control of operation of the shaded pole relay is desired.
- The inertia of the disc provides the time delay characteristics.

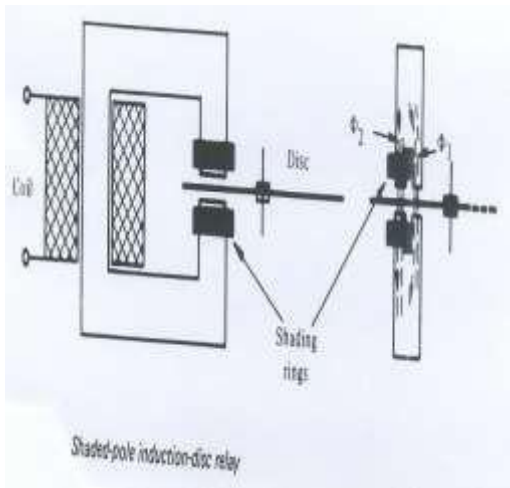

(i)

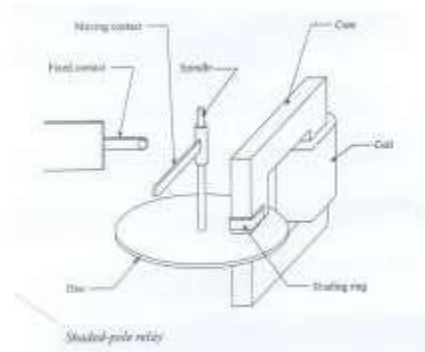

(ii)

Fig-5.7

Watt hour –meter structure

- This structure gets its name from the fact that it is used in watt hour meters.
- As shown in the top figure below, it contains two separate coils on two different magnetic circuit, each of which produces one of two necessary fluxes for driving the rotor, which is also a disc

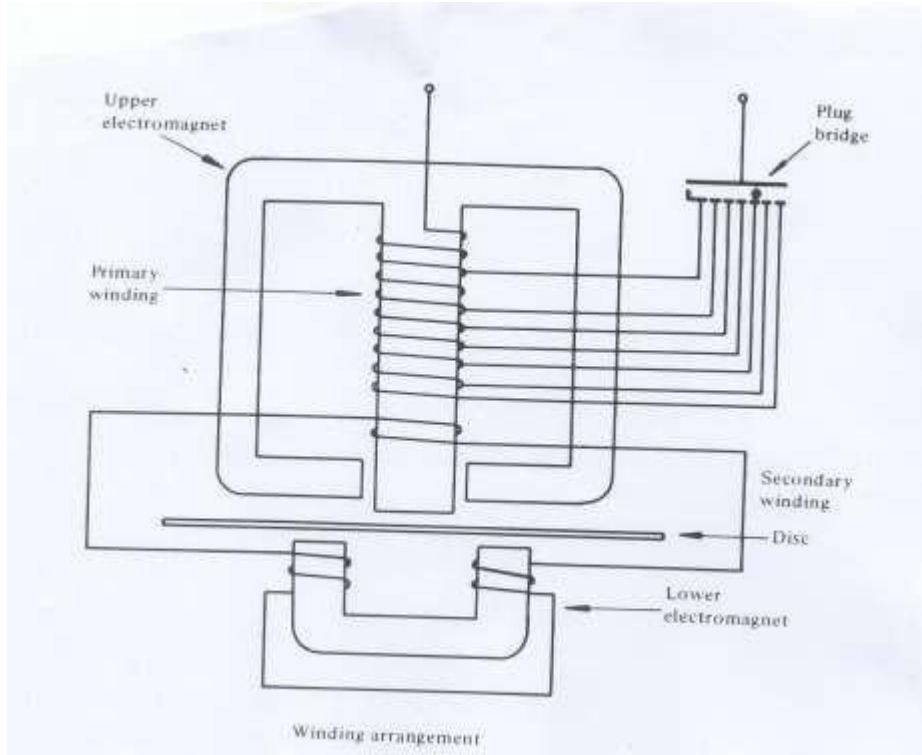

Fig-5.8

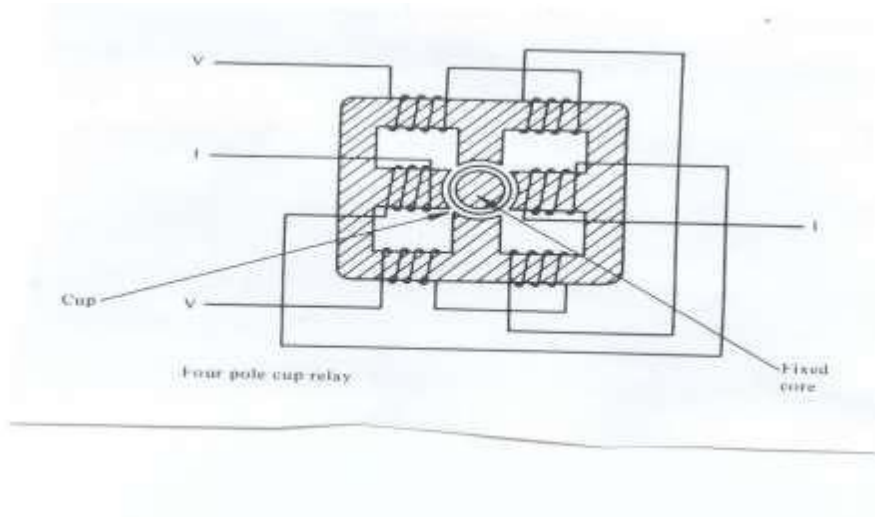

Fig-5.9

b) Induction-cup

- This type of relay has a cylinder similar to a cup which can rotate in the annular air gap between the poles & the fixed central core. The figure is shown above.
- The operation of this relay is similar to that of an induction motor with salient poles for the windings of the stator.
- The movement of the cup is limited to a small amount by the contact & the stops.
- A special spring provides restraining torque.
- The cup type of relay has a small inertia & is therefore principally used when high speed operation is required, for example in instantaneous units.

General Torque equation of Relay Before understanding about different other relays, it is first necessary to know the general torque equation that defines any relay. The following equation defines torque in general.

$$T = K_1 I^2 + K_2 V^2 + K_3 VI \cos(\theta - \tau) + K_4$$

Where, ϑ is the power factor angle and τ is the angle of maximum torque. As seen from the equation, the component of torques may be proportional to current, voltage, power and combination of the three quantities. The constant K_4 is meant for the spring constant of the relay. Depending upon the type of relay, the one or several of the four constants K_1 – K_4 are either zero or non zero. In the subsequent discussions this will be elaborated when different types of relays are discussed.

$$T = K_1 I^2 + K_4$$

RELAY TIMING CIRCUIT:

An important characteristic of a relay is its time of operation. By the Relay Timing Circuit of operation is meant length of the time from the instant when the actuating element is energized to the instant when the relay contacts are closed. Sometimes it is desirable and necessary to control the operating time of a relay. For this purpose, mechanical accessories are used with relays.

1. Instantaneous relay:

An instantaneous relay is one in which no intentional time delay is provided. In this case, the relay contacts are closed immediately after current in the relay coil exceeds the minimum calibrated value. Fig. shows an instantaneous solenoid type of relay. Although there will be a short time interval between the instant of pickup and the closing of relay contacts, no intentional time delay has been added. The instantaneous relays have operating time less than 0.1 second. The instantaneous relay is effective only where the impedance between the relay and source is small compared to the protected section impedance. The operating time of instantaneous relay is sometimes expressed in cycles based on the power-system frequency e.g. one-cycle would be $1/50$ second in a 50-cycle system.

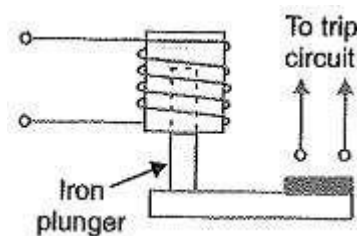
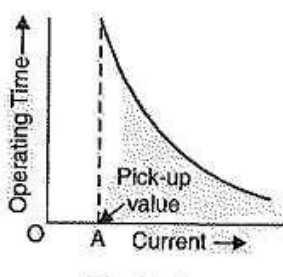

Fig-5.10

2. Inverse-time relay:

An inverse-time relay is one in which the operating time is approximately inversely proportional to the magnitude of the actuating quantity. Fig.5.11 (i) shows the time-current characteristics of an inverse current relay. At values of current less than pickup, the Relay Timing Circuit never operates. At higher values, the time of operation of the relay decreases steadily with the increase of current. The inverse-time delay can be achieved by associating mechanical accessories with relays.



(ii)

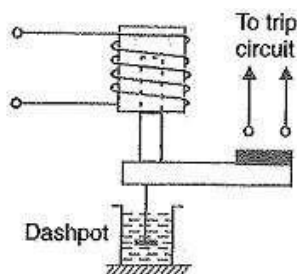

(ii)

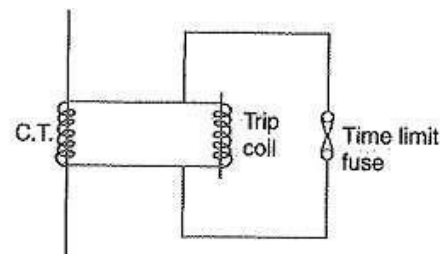

(iii)

Fig-5.11

- In an induction relay, the inverse-time delay can be achieved by positioning a permanent magnet (known as a drag magnet) in such a way that relay disc cuts the flux between the poles of the magnet. When the disc moves, currents set up in it produce a drag on the disc which slows its motion.
- In other types of relays, the inverse time delay can be introduced by oil dashpot or a time-limit fuse. Fig.(ii) shows an inverse time solenoid relay using oil dashpot. The piston in the oil dashpot attached to the moving plunger slows its upward motion. At a current value just equal to the pickup, the plunger moves slowly and time delay is at a maximum. At higher values of relay current, the delay time is shortened due to greater pull on the plunger.
- The inverse-time characteristic can also be obtained by connecting a time-limit fuse in parallel with the trip coil terminals as shown in Fig.(iii). The shunt path formed by time-limit fuse is of negligible impedance as compared with the relatively high impedance of the trip coil. Therefore, so long as the fuse remains intact, it will divert practically the whole secondary current of CT from the trip coil. When the secondary current exceeds the current carrying capacity of the fuse, the fuse will blow and the whole current will pass through the trip coil, thus opening the circuit breaker. The time-lag between the incidence of excess current and the tripping of the breaker is governed by the characteristics of the fuse. Careful selection of the fuse can give the desired inverse-time characteristics, although necessity for replacement after operation is a disadvantage.

3. Definite time lag relay:

In this type of relay, there is a definite time elapse between the instant of pickup and the closing of relay contacts. This particular time setting is independent of the amount of current through the relay coil ; being the same for all values of current in excess of the pickup value. It may be worthwhile to mention here that practically all inverse-time relays are also provided with definite minimum time feature in order that the Relay Timing Circuit may never become instantaneous in its action for very long overloads.

IMPORTANT TERMS

1.Pick-up current:

It is the minimum current in the relay coil at which the relay starts to operate. So long as the current in the relay is less than the pick-up value, the relay does not operate and the breaker controlled by it remains in the closed position. However, when the relay coil current is equal to or greater than the pickup value, the Relay Timing Circuit operates to energise the trip coil which opens the circuit breaker.

2.Current setting:

It is often desirable to adjust the pick-up current to any required value. This is known as current setting and is usually achieved by the use of tapings on the relay operating coil.

$$\text{Pick-up current} = \text{Rated secondary current of C.T.} \times \text{Current setting}$$

4. Plug-setting multiplier (P.S.M.):

It is the ratio of fault current in relay coil to the pick-up current i.e.

$$\text{P.S.M.} = \frac{\text{Fault current in relay coil}}{\text{Pick - up current}}$$

$$= \frac{\text{Fault current in relay coil}}{\text{Rated secondary current of CT} \times \text{Current setting}}$$

5. Time-setting multiplier:

A relay is generally provided with control to adjust the time of operation. This adjustment is known as time-setting multiplier. The time-setting dial is calibrated from 0 to 1 in steps of 0.05 sec (see Fig-5.11.(iv)). These figures are multipliers to be used to convert the time derived from time/P.S.M. curve into the actual operating time.

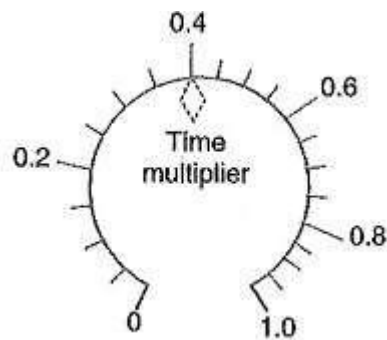

Fig-5.11(iv)

6. Time/P.S.M. Curve:

Fig 5.12. shows the curve between time of operation and plug setting multiplier of a typical relay. The horizontal scale is marked in terms of plug-setting multiplier and represents the number of times the relay current is in excess of the current setting. The vertical scale is marked in terms of the time required for relay operation. If the P.S.M. is 10, then the time of operation (from the curve) is 3 seconds. The actual time of operation is obtained by multiplying this time by the time-setting multiplier.

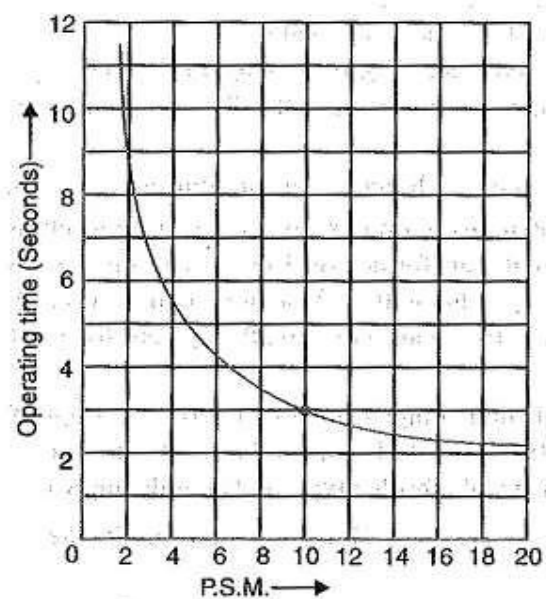

Fig-5.12

Induction Type Overcurrent Relay(Non-Directional):

This Induction Type Overcurrent Relay works on the induction principle and initiates corrective measures when current in the circuit exceeds the predetermined value. The actuating source is a current in the circuit supplied to the relay from a current transformer. These relays are used on a .c. circuits only and can operate for fault current flow in either direction.

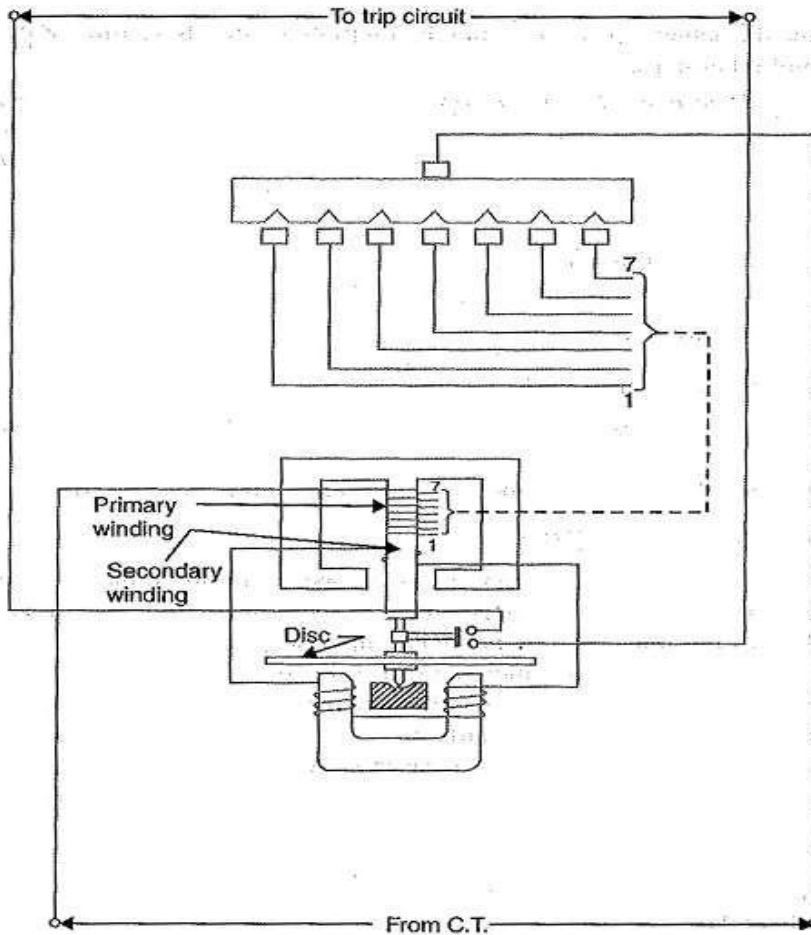

Fig-5.13

Constructional details:

The above Fig-5.13 shows the important constructional details of a typical non-directional induction type overcurrent relay. It consists of a metallic (aluminium) disc which is free to rotate in between the poles of two electromagnets. The upper electromagnet has a primary and a secondary winding. The primary is connected to the secondary of a C.T. in the line to be protected and is tapped at intervals. The tappings are connected to a plug-setting bridge by which the number of active turns on the relay operating coil can be varied, thereby giving the desired current setting. The secondary winding is energized by induction from primary and is connected in series with the winding on the lower magnet. The controlling torque, is provided by a spiral spring.

The spindle of the disc carries a moving contact which bridges two fixed contacts (connected to trip circuit) when the disc rotates through a pre-set angle. This angle can be adjusted to any value between 0° and 360° . By adjusting this angle, the travel of the moving contact can be adjusted and hence the relay can be given any desired time setting.

Operation:

The driving torque on the aluminium disc is set up due to the induction principle as discussed. This torque is opposed by the restraining torque provided by the spring. Under normal operating conditions, restraining torque is greater than the driving torque produced by the relay coil current, Therefore, the aluminium disc remains stationary. However, if the current in the protected circuit exceeds the pre-set value, the driving torque becomes greater than the restraining torque. Consequently, the disc rotates and the moving contact bridges the fixed contacts when the disc has rotated through a pre-set angle. The trip circuit operates the circuit breaker which isolates the faulty section.

Induction Type Directional Overcurrent Relay:

The directional power relay is unsuitable for use as a directional protective relay under short-circuit conditions. When a short-circuit occurs, the system voltage falls to a low value and there may be insufficient torque developed in the relay to cause its operation. This difficulty is overcome in the Induction Type Directional Overcurrent Relay which is designed to be almost independent of system voltage and power factor.

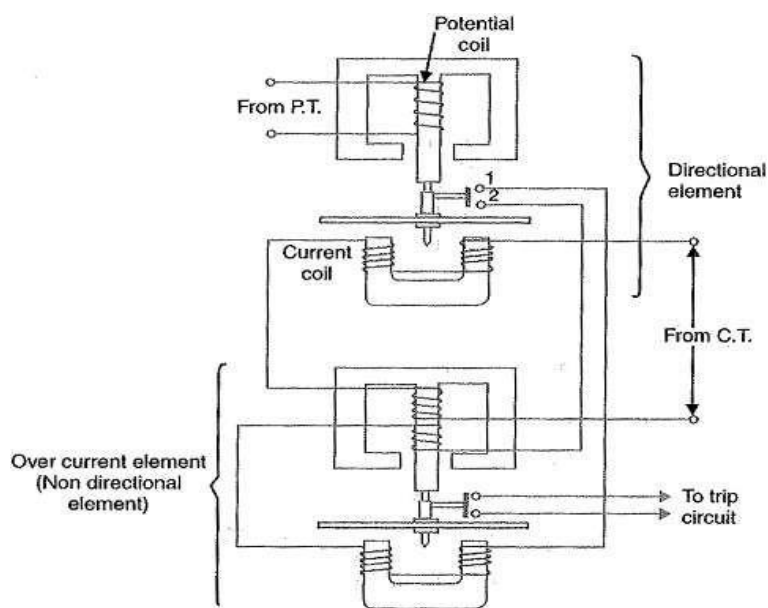

Fig-5.14

Constructional details:

Fig-5.14 shows the constructional details of a typical Induction Type Directional Overcurrent Relay. It consists of two relay elements mounted on a common case viz.

1. Directional element: It is essentially a directional power relay which operates when power flows in a specific direction. The potential coil of this element is connected through a potential transformer (P.T.) to the system voltage. The current coil of the element is energised through a C.T. by the circuit current. This winding is carried over the upper magnet of the non-directional element. The trip contacts (1 and 2) of the directional element are connected in series with the secondary circuit of the overcurrent element. Therefore, the latter element cannot start to operate until its secondary circuit is completed. In other words, the directional element must operate first (i.e. contacts 1 and 2 should close) in order to operate the overcurrent element.

2. Non-directional element: It is an overcurrent element similar in all respects to a non-directional overcurrent relay described. The spindle of the disc of this element carries a moving contact which closes the fixed contacts (trip circuit contacts) after the operation of directional element.

It may be noted that plug-setting bridge is also provided in the relay for current setting but has been omitted in the figure for clarity and simplicity. The tapings are provided on the upper magnet of overcurrent element and are connected to the bridge.

Operation:

Under normal operating conditions, power flows in the normal direction in the circuit protected by the relay. Therefore, Induction Type Directional Overcurrent Relay (upper element) does not operate, thereby keeping the overcurrent element (lower element) unenergised. However, when a short-circuit occurs, there is a tendency for the current or power to flow in the reverse direction. Should this happen, the disc of the upper element rotates to bridge the fixed contacts 1 and 2. This completes the circuit for overcurrent element.

The disc of this element rotates and the moving contact attached to it closes the trip circuit. This operates the circuit breaker which isolates the faulty section. The two relay elements are so arranged that final tripping of the current controlled by them is not made till the following conditions are satisfied

1. current flows in a direction such as to operate the directional element.
2. current in the reverse direction exceeds the pre-set value.
3. excessive current persists for a period corresponding to the time setting of overcurrent element.

Induction Type Directional Power Relay:

This Induction Type Directional Power Relay operates when power in the circuit flows in a specific direction. Unlike a non-directional overcurrent relay, a directional power relay is so designed that it obtains its operating torque by the interaction of magnetic fields derived from both voltage and current source of the circuit it protects. Thus this type of relay is essentially a wattmeter and the direction of the torque set up in the relay depends upon the direction of the current relative to the voltage, with which it is associated.

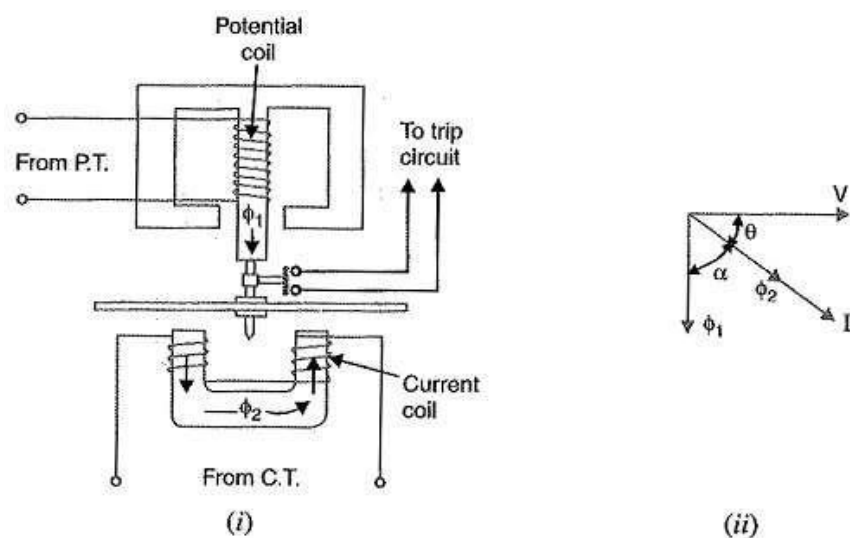

Fig-5.15

Constructional details:

Fig.5.15 shows the essential parts of a typical induction type directional power relay. It consists of an aluminum disc which is free to rotate in between the poles of two electromagnets. The upper electromagnet carries a winding (called potential coil) on the central limb which is connected through a potential transformer (P.T.) to the circuit voltage source. The lower electromagnet has a separate winding (called current coil) connected to the secondary of C.T. in the line to be protected. The current coil is provided with a number of tapings connected to the plug-setting Midge (not shown for clarity). This permits to have any desired current setting. The restraining torque is provided by a spiral spring.

The spindle of the disc carries a moving contact which bridges two fixed contacts when the disc has rotated through a pre-set angle. By adjusting this angle, the travel of the moving disc can be adjusted and hence any desired time-setting can be given to the relay.

Operation:

The flux Φ_1 due to current in the potential coil will be nearly 90° lagging behind the applied voltage V . The flux Φ_2 due to current coil will be nearly in phase with the operating current I .

[See vector diagram in Fig.(ii)]. The interaction of fluxes Φ_1 and Φ_2 with the eddy currents induced in the disc produces a driving torque given by :

$$\begin{aligned}
 T &\propto \phi_1 \phi_2 \sin \alpha && \text{[See Art. 21.5]} \\
 \text{Since } \phi_1 &\propto V, \quad \phi_2 \propto I \quad \text{and} \quad \alpha = 90 - \theta \\
 T &\propto V I \sin (90 - \theta) \\
 &\propto V I \cos \theta \\
 &\propto \text{power in the circuit}
 \end{aligned}$$

It is clear that the direction of driving torque on the disc depends upon the direction of power flow in the circuit to which the relay is associated. When the power in the circuit flows in the normal direction, the driving torque and the restraining torque (due to spring) help each other to turn away the moving contact from the fixed contacts. Consequently, the relay remains inoperative. However, the reversal of current in the circuit reverses the direction of driving torque on the disc. When the reversed driving torque is large enough, the disc rotates in the reverse direction and the moving contact closes the trip circuit. This causes the operation of the circuit breaker which disconnects the faulty section.

DIFFERENTIAL RELAYS:

Most of the relays discussed so far relied on excess of current for their operation. Such relays are less sensitive because they cannot make correct distinction between heavy load conditions and minor fault conditions. In order to overcome this difficulty, differential relays are used.

A differential relays is one that operates when the phasor difference of two or more similar electrical quantities exceeds a pre-determined value.

Thus a current differential relays is one that compares the current entering a section of the system with the current leaving the section. Under normal operating conditions, the two currents are equal but as soon as a fault occurs, this condition no longer applies. The difference between the incoming and outgoing currents is arranged to flow through the operating coil of the relay. If this differential

current is equal to or greater than the pickup value, the relay will operate and open the circuit breaker to isolate the faulty section.

It may be noted that almost any type of relay when connected in a particular way can be made to operate as a differential relay. In other words, it is not so much the relay construction as the way the relay is connected in a circuit that makes it a differential relays. There are two fundamental systems of differential or balanced protection viz.

1. Current balance protection

Fig.5.16 shows an arrangement of an overcurrent relay connected to operate as a differential relay. A pair of identical current transformers are fitted on either end of the section to be protected (alternator winding in this case). The secondaries of CT's are connected in series in such a way that they carry the induced currents in the same direction. The operating coil of the overcurrent relay is connected across the CT secondary circuit. This differential relays compares the current at the two ends of the alternator winding.

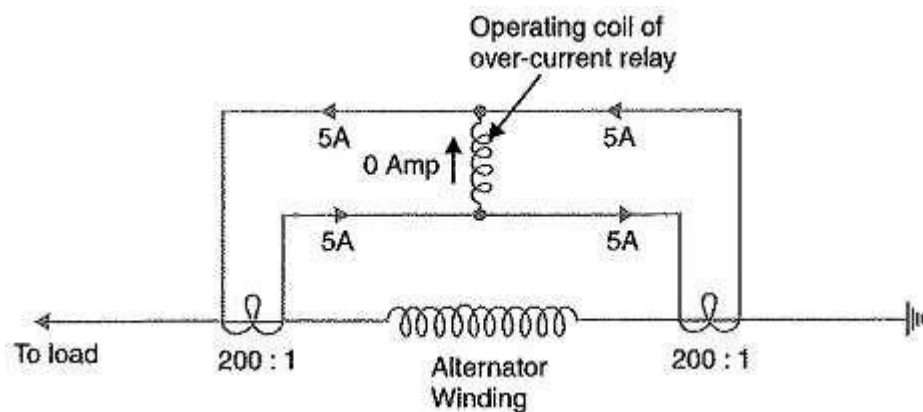
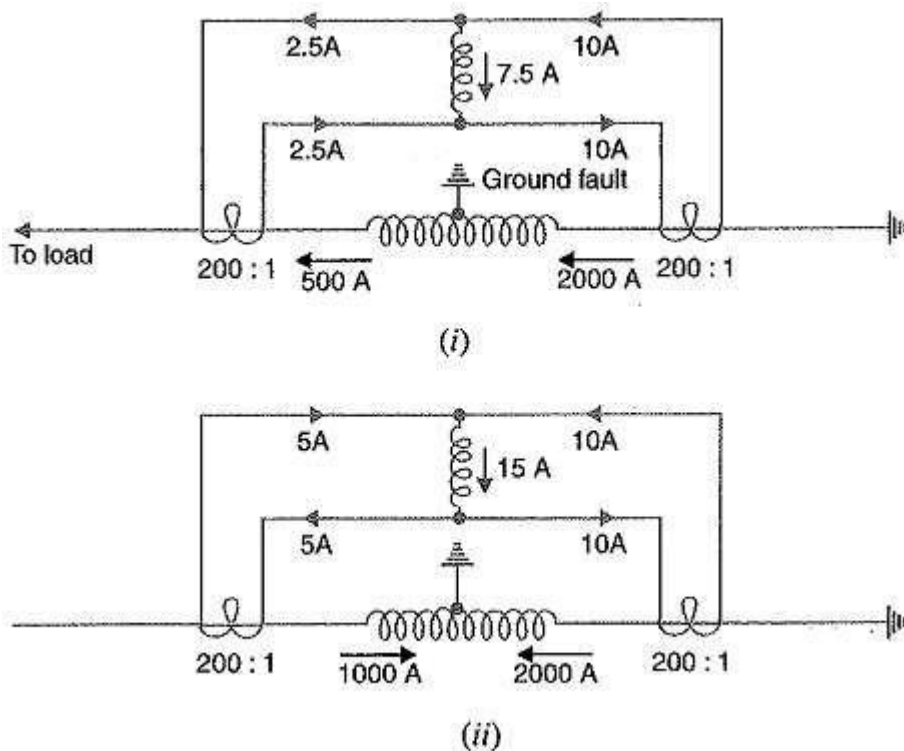

Fig-5.16

Under normal operating conditions, suppose the alternator winding carries a normal current of 1000 A. Then the currents in the two secondaries of CT's are equal. These currents will merely circulate between the two CT's and no current will flow through the differential relays. Therefore, the relay remains inoperative. If a ground fault occurs on the alternator winding as shown in Fig. (i), the two secondary currents will not be equal and the current flows through the operating coil of the relay, causing the relay to operate. The amount of current flow through the relay will depend upon the way the fault is being fed.



(i) If some current (500 A in this case) flows out of one side while a larger current (2000 A) enters the other side as shown in Fig. (i), then the difference of the CT secondary currents i.e. $10 - 2.5 = 7.5$ A will flow through the relay.

(ii) If current flows to the fault from both sides as shown in Fig.(ii), then sum of CT secondary currents i.e. $10 + 5 = 15$ A will flow through the relay.

Disadvantages

- The impedance of the pilot cables generally causes a slight difference between the currents at the two ends of the section to be protected. If the relay is very sensitive, then the small differential current flowing through the relay may cause it to operate even under no fault
- Pilot cable capacitance causes incorrect operation of the relay when a large through-current
- Accurate matching of current transformers cannot be achieved due to pilot circuit impedance.

2. Voltage Balance Differential Relays:

Fig.5.17 shows the arrangement of voltage balance protection. In this scheme of protection, two similar current transformers are connected at either end of the element to be protected (e.g. an alternator winding) by means of pilot wires. The secondaries of current transformers are connected in series with a relay in such way that under normal conditions, their induced e.m.f.'s are in opposition.

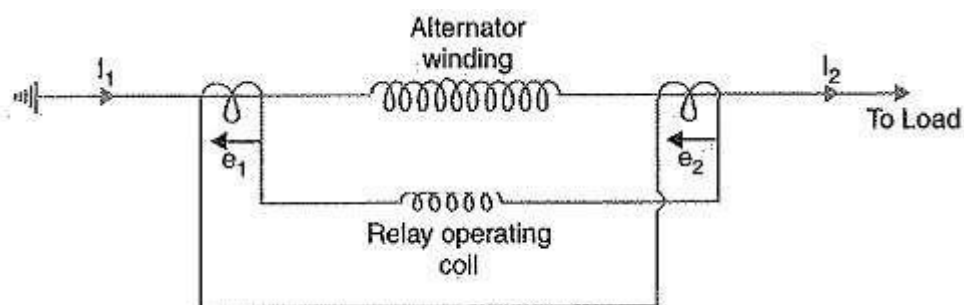

Fig-5.17

Under healthy conditions, equal currents ($I_1 = I_2$) flow in both primary windings. Therefore, the secondary voltages of the two transformers are balanced against each other and no current will flow through the relay operating coil. When a fault occurs in the protected zone, the currents in the two primaries will differ from one another (i.e. $I_1 \neq I_2$) and their secondary voltages will no longer be in balance. This voltage difference will cause a current to flow through the operating coil of the relay which closes the trip circuit.

Disadvantages

The voltage balance system suffers from the following drawbacks:

- A multi-gap transformer constriction is required to achieve the accurate balance between current transformer pairs.
- The system is suitable for protection of cables of relatively short lengths due to the capacitance of pilot wires. On long, cables, the charging current may be sufficient to operate the relay even if a perfect balance of current transformers is attained.

TYPES OF PROTECTION:

When a fault occurs on any part of electric power system, it must be cleared quickly in order to avoid damage and/or interference with the rest of the system. It is a usual practice to divide the Types of Protection scheme into two classes viz. primary protection and back-up protection.

1. Primary Protection:

It is the protection scheme which is designed to protect the component parts of the power system. Thus referring to below Fig. each line has an overcurrent relay that protects the line. If a fault occurs on any line, it will be cleared by its relay and circuit breaker. This forms the primary or main protection and serves as the first line of defence.

The service record of primary relaying is very high with well over ninety percent of all operations being correct. However, sometimes faults are not cleared by primary relay system because of trouble within the relay, wiring system or breaker. Under such conditions, back-up protection does the required job.

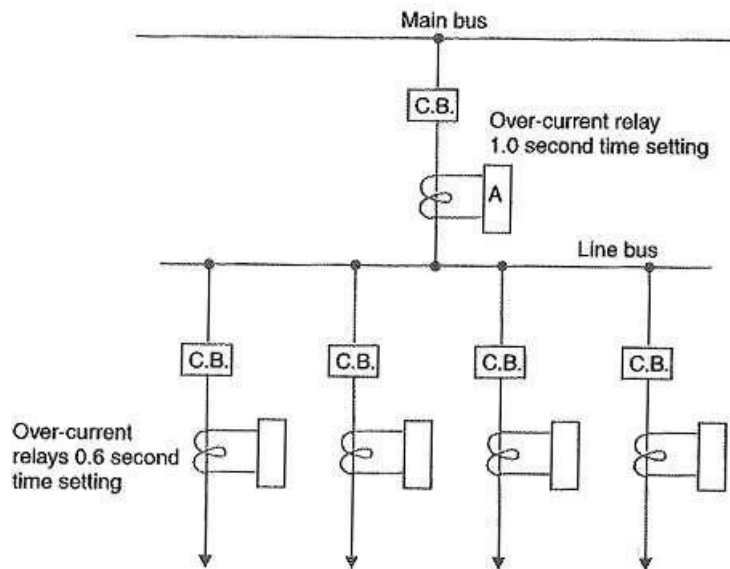

Fig-5.18

2. Back-up protection:

It is the second line of defense in case of failure of the primary protection. It is designed to operate with sufficient time delay so that primary relaying will be given enough time to function if it is able to. Thus referring to above fig-5.18, relay A provides back-up protection for each of the four lines. If a line fault is not cleared by its relay and breaker, the relay A on the group breaker will operate after a definite time delay and clear the entire group of lines.

It is evident that when back-up relaying functions, a larger part is disconnected than when primary relaying functions correctly. Therefore, greater emphasis should be placed on the better maintenance of primary relaying.

Chapter VI

Protection of Electrical power equipment and Lines

PROTECTION OF ALTERNATORS:

The generating units, especially the larger ones, are relatively few in number and higher in individual cost than most other equipment's. Therefore, it is desirable and necessary to provide Protection of Alternators to cover the wide range of faults which may occur in the modern generating plant.

Some of the important faults which may occur on an alternator are :

1. Failure of Prime-Mover:

When input to the prime-mover fails, the alternator runs as a synchronous motor and draws some current from the supply system. This motoring conditions is known as "inverted running".

- In case of turbo-alternator sets, failure of steam supply may cause inverted running. If the steam supply is gradually restored, the alternator will pick up load without disturbing the system. If the steam failure is likely to be prolonged, the machine can be safely isolated by the control room attendant since this condition is relatively harmless. Therefore, automatic protection is not required.
- In case of hydro-generator sets, Protection of Alternators against inverted running is achieved by providing mechanical devices on the water-wheel. When the water flow drops to an insufficient rate to maintain the electrical output, the alternator is disconnected from the Therefore, in this case also electrical protection is not necessary.
- Diesel engine driven alternators, when running inverted, draw a considerable amount of power from the supply system and it is a usual practice to provide Protection of Alternators against motoring in order to avoid damage due to possible mechanical seizure. This is achieved by applying reverse power relays to the alternators which *isolate the latter during their motoring action. It is essential that the reverse power relays have time-delay in operation in order to prevent inadvertent tripping during system disturbances caused by faulty synchronizing and phase swinging.

2. Failure of field:

The chances of field failure of alternators are undoubtedly very rare. Even if it does occur, no immediate damage will be caused by permitting the alternator to run without a field for a short-period. It is sufficient to rely on the control room attendant to disconnect the faulty alternator manually from the system bus-bars. Therefore, it is a universal practice not to provide automatic protection against this contingency.

3. Overcurrent:

It occurs mainly due to partial breakdown of winding insulation or due to overload on the supply system. Overcurrent protection for alternators is considered unnecessary because of the following reasons:

- The modern tendency is to design alternators with very high values of internal impedance so that they will stand a complete short-circuit at their terminals for sufficient time without serious overheating. On the occurrence of an overload, the alternators can be disconnected manually.
- The disadvantage of using overload Protection of Alternators is that such a protection might disconnect the alternators from the power plant bus on account of some momentary troubles outside the plant and, therefore, interfere with the continuity of electric service.

4. Overspeed:

The chief cause of over speed is the sudden loss of all or the major part of load on the alternator. Modern alternators are usually provided with mechanical centrifugal devices mounted on their driving shafts to trip the main valve of the prime-mover when a dangerous over speed occurs.

5. Over-voltage:

The field excitation system of modern alternators is so designed that over-voltage conditions at normal running speeds cannot occur. However, over voltage in an alternator occurs when speed of the prime-mover increases due to sudden loss of the alternator load.

In case of steam-turbine driven alternators, the control governors are very sensitive to speed variations. They exercise a continuous check on over speed and thus prevent the occurrence of over-voltage on the generating unit. Therefore, over-voltage protection is not provided on turbo-alternator sets.

In case of hydro-generator, the control governors are much less sensitive and an appreciable time may elapse before the rise in speed due to loss of load is checked. The over-voltage during this time may reach a value which would over-stress the stator windings and insulation breakdown may occur. It is, therefore, a usual practice to provide over-voltage protection on hydro-generator units. The over-voltage relays are operated from a voltage supply derived from the generator terminals. The relays are so arranged that when the generated voltage rises 20% above the normal value, they operate to

- trip the main circuit breaker to disconnect the faulty alternator from the system
- disconnect the alternator field circuit

6. Unbalanced loading:

Unbalanced loading means that there are different phase currents in the alternator. Unbalanced loading arises from faults to earth or faults between phases on the circuit external to the alternator. The unbalanced currents, if allowed to persist, may either severely burn the mechanical fixings of the rotor core or damage the field winding.

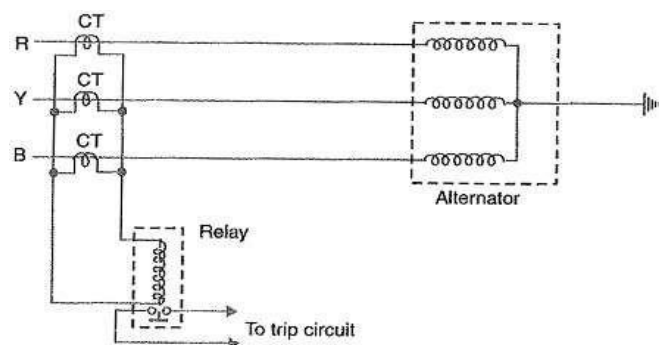

Fig-6.1

Fig-6.1 shows the schematic arrangement for the Protection of Alternators against unbalanced loading. The scheme comprises three line current transformers, one mounted in each phase, having their secondaries connected in parallel. A relay is connected in parallel across the transformer secondaries. Under normal operating conditions, equal currents flow through the different phases of the alternator and their algebraic sum is zero. Therefore, the sum of the currents flowing in the secondaries is also zero and no current flows through the operating coil of the relay. However, if unbalancing occurs, the currents induced in the secondaries will be different and the resultant of these currents will flow through the relay. The operation of the relay will trip the circuit breaker to disconnect the alternator from the system.

7. Stator winding faults:

These faults occur mainly due to the insulation failure of the stator windings. The main types of stator winding faults, in order of importance are :

- fault between phase and ground
- fault between phases
- inter-turn fault involving turns of the same phase winding

The stator winding faults are the most dangerous and are likely to cause considerable damage to the expensive machinery. Therefore, automatic protection is absolutely necessary to clear such faults in the quickest possible time in order to minimize the extent of damage. For Protection of Alternators against such faults, differential method of protection (also known as Merz-Price system) is most commonly employed due to its greater sensitivity and reliability.

DIFFERENTIAL PROTECTION OF ALTERNATORS:

The most common system used for the protection of stator winding faults employs circulating-current principle. In this scheme of Differential Protection of Alternators, currents at the two ends of the protected section are compared. Under normal operating conditions, these currents are equal but may become unequal on the occurrence of a fault in the protected section. The difference of the currents under fault conditions is arranged to pass through the operating coil of the relay. The relay then closes its contacts to isolate protected section from the system. This form of protection is also known as Merz-Price Circulating Current Scheme

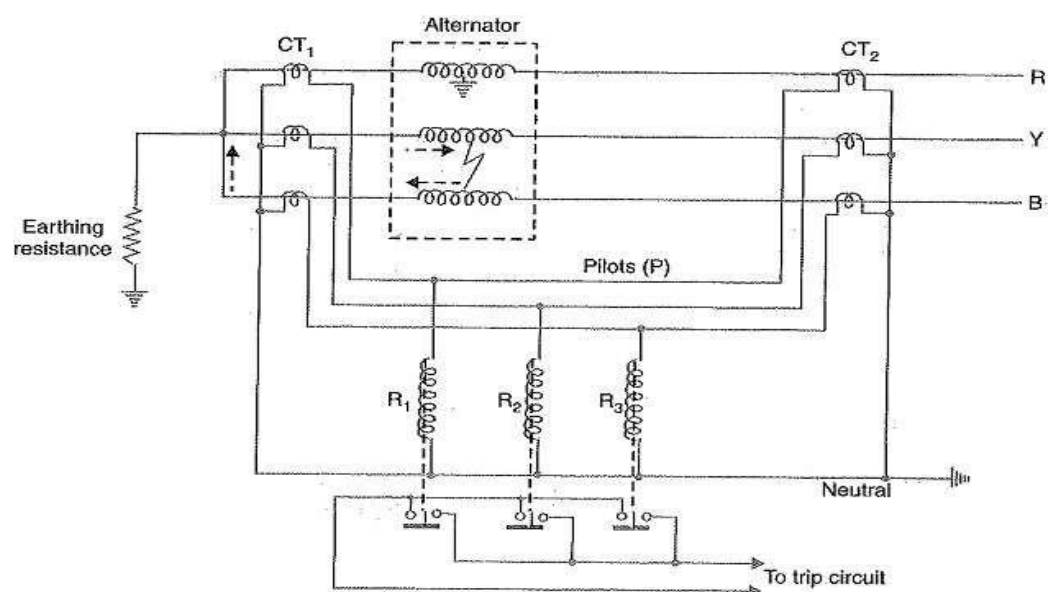

Fig-6.2

Schematic arrangement:

Fig-6.2 shows the schematic arrangement of Differential Protection of Alternators for a 3-phase alternator. Identical current transformer pairs CT_1 and CT_2 are placed on either side of each phase of the stator windings. The secondaries of each set of current transformers are connected in star; the two neutral points and the corresponding terminals of the two star groups being connected together by means of a four-core pilot cable. Thus there is an independent path for the currents circulating in each pair of current transformers and the corresponding pilot P.

The relay coils are connected in star, the neutral point being connected to the current-transformer common neutral and the outer ends one to each of the other three pilots. In order that burden on each current transformer is the same, the relays are connected across equipotential points of the three pilot wires and these equipotential points would naturally be located at the middle of the pilot wires. The relays are generally of electromagnetic type and are arranged for instantaneous action since fault should be cleared as quickly as possible.

Operation:

Referring to Fig.6.2 it is clear that the relays are connected in shunt across each circulating path. Therefore, the circuit of Fig. can be shown in a simpler form in Fig. Under normal operating conditions, the current at both ends of each winding will be equal and hence the currents in the secondaries of two CTs connected in any phase will also be equal. Therefore, there is balanced circulating current in the pilot wires and no current flows through the operating coils (R_1 , R_2 and R_3) of the relays. When an earth-fault or phase-to-phase fault occurs, this condition no longer holds good and the differential current flowing through the relay circuit operates the relay to trip the circuit breaker.

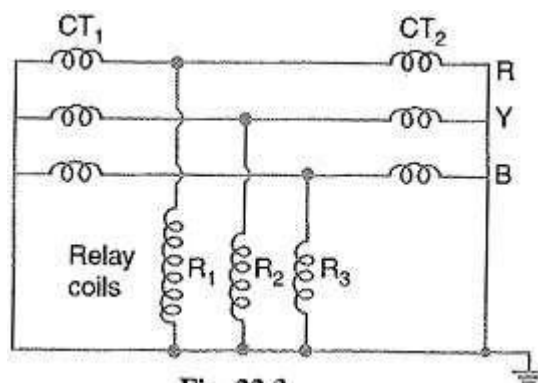

Fig-6.3

(i) Suppose an earth fault occurs on phase R due to breakdown of its insulation to earth as shown in Fig-6.3. The current in the affected phase winding will flow through the core and frame of the machine to earth, the circuit being completed through the neutral earthing resistance. The currents in the secondaries of the two CTs in phase R will become unequal and the difference of the two currents will flow through the corresponding relay coil (i.e. R_1), returning via the neutral pilot. Consequently, the relay operates to trip the circuit breaker.

(ii) Imagine that now a short-circuit fault occurs between the phases Y and B as shown in Fig. The short-circuit current circulates via the neutral end connection through the two windings and through the fault as shown by the dotted arrows. The currents in the secondaries of two CTs in each affected

phase will become unequal and the differential current will flow through the operating coils of the relays (i.e. R_2 and R_3) connected in these phases. The relay then closes its contacts to trip the circuit breaker. It may be noted that the relay circuit is so arranged that its energizing causes (i) opening of the breaker connecting the alternator to the bus-bars and (ii) opening of the field circuit of the alternator.

Limitations:

The two circuits for alternator protection shown above have their own limitations. It is a general practice to use neutral earthing resistance in order to limit the destructive effects of earth-fault currents. In such a situation, it is impossible to protect whole of the stator windings of a star-connected alternator during earth-faults. When an earth-fault occurs near the neutral point, there may be insufficient voltage across the short-circuited portion to drive the necessary current round the fault circuit to operate the relay. The magnitude of unprotected zone depends upon the value of earthing resistance and relay setting.

Makers of protective gear speak of "protecting 80% of the winding" which means that faults in the 20% of the winding near the neutral point cannot cause tripping i.e. this portion is unprotected. It is a usual practice to protect only 85% of the winding because the chances of an earth fault occurring near the neutral point are very rare due to the uniform insulation of the winding throughout.

BALANCED EARTH FAULT PROTECTION:

In small-size alternators, the neutral ends of the three-phase windings are often connected internally to a single terminal. Therefore, it is not possible to use Merz-Price circulating current principle described above because

there are no facilities for accommodating the necessary current transformers in the neutral connection of each phase winding. Under these circumstances, it is considered sufficient to provide protection against earth-faults only by the use of Balanced Earth Fault Protection scheme. This scheme provides no protection against phase-to-phase faults, unless and until they develop into earth-faults, as most of them will.

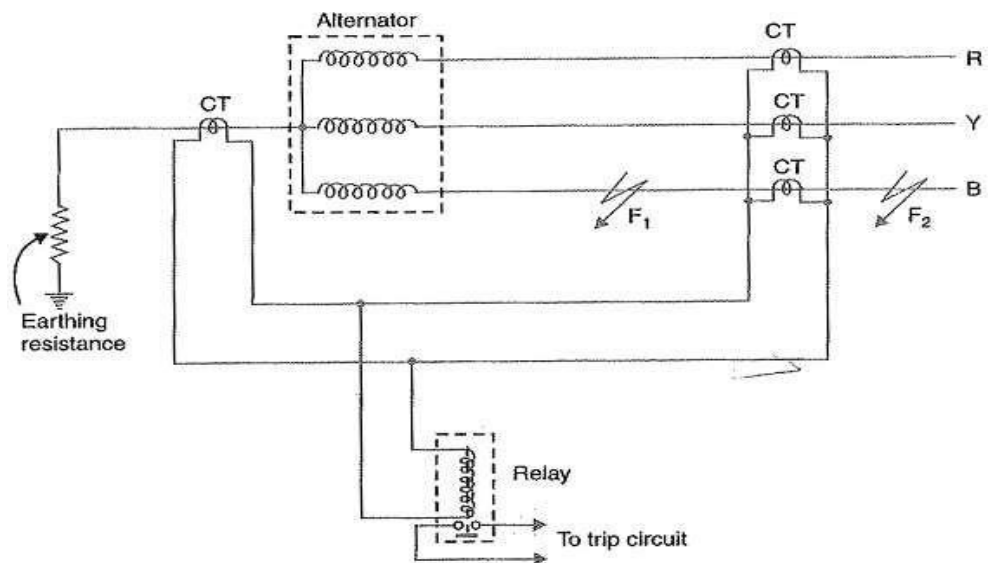

Fig-6.4

Schematic arrangement:

Fig.6.4 shows the schematic arrangement of a Balanced Earth Fault Protection for a 3-phase alternator. It consists of three line current transformers, one mounted in each phase, having their secondaries connected in parallel with that of a single current transformer in the conductor joining the star point of the alternator to earth. A relay is connected across the transformers secondaries. The protection against earth faults is limited to the region between the neutral and the line current transformers.

Operation:

Under normal operating conditions of Balanced Earth Fault Protection, the currents flowing in the alternator leads and hence the currents flowing in secondaries of the line current transformers add to zero and no current flows through the relay. Also under these conditions, the current in the neutral wire is zero and the secondary of neutral current transformer supplies no current to the relay.

If an earth-fault develops at F_2 external to the protected zone, the sum of the currents at the terminals of the alternator is exactly equal to the current in the neutral connection and hence no current flows through the relay. When an earth-fault occurs at F_1 or within the protected zone, these currents are no longer equal and the differential current flows through the operating coil of the relay. The relay then closes its contacts to disconnect the alternator from the system.

PROTECTION OF TRANSFORMERS:

Transformers are static devices, totally enclosed and generally oil immersed. Therefore, chances of faults occurring on them are very rare. However, the consequences of even a rare fault may be very serious unless the transformer is quickly disconnected from the system. This necessitates to provide adequate automatic Protection of Transformers against possible faults.

Small distribution transformers are usually connected to the supply system through series fuses instead of circuit breakers. Consequently, no automatic protective relay equipment is required. However, the probability of faults on power transformers is undoubtedly more and hence automatic protection is absolutely necessary.

Common transformer faults: As compared with generators, in which many abnormal conditions may arise, power transformers may suffer only from :

- open circuits
- overheating
- winding short-circuits g. earth-faults, phase-to-phase faults and inter-turn faults.

An open circuit in one phase of a 3-phase transformer may cause undesirable heating. In practice, relay protection is not provided against open circuits because this condition is relatively harmless. On the occurrence of such a fault, the transformer can be disconnected manually from the system.

Overheating of the transformer is usually caused by sustained overloads or short-circuits and very occasionally by the failure of the cooling system. The relay protection is also not provided against this contingency and thermal accessories are generally used to sound an alarm or control the banks of fans.

Winding short-circuits (also called internal faults) on the transformer arise from deterioration of winding insulation due to overheating or mechanical injury. When an internal fault occurs, the transformer must be disconnected quickly from the system because a prolonged arc in the transformer may cause oil fire. Therefore, relay protection is absolutely necessary for internal faults.

Protection Systems for Transformers:

For protection of generators, Merz-Price circulating-current system is unquestionably the most satisfactory. Though this is largely true of Protection of Transformers, there are cases where circulating current system offers no particular advantage over other systems or impracticable on account of the troublesome conditions imposed by the wide variety of voltages, currents and earthing conditions invariably associated with power transformers. Under such circumstances, alternative protective

systems are used which in many cases are as effective as the circulating-current system. The principal relays and systems used for Protection of Transformers are :

- Buchholz devices providing protection against all kinds of incipient faults i.e. slow-developing faults such as insulation failure of windings, core heating, fall of oil level due to leaky joints etc.
- Earth fault relays providing protection against earth-faults only.
- Overcurrent relays providing protection mainly against phase-to-phase faults and overloading.
- Differential system (or circulating-current system) providing protection against both earth and phase faults.

The complete Protection of Transformers usually requires the combination of these systems. Choice of a particular combination of systems may depend upon several factors such as

- Size of the transformer
- Type of cooling
- Location of transformer in the network
- Nature of load supplied and
- Importance of service for which transformer is required.

Buchholz Relay:

Buchholz Relay is a gas-actuated relay installed in oil immersed transformers for protection against all kinds of faults. Named after its inventor, Buchholz, it is used to give an alarm in case of incipient (i.e. slow-developing) faults in the transformer and to disconnect the transformer from the supply in the event of severe internal faults. It is usually installed in the pipe connecting the conservator to the main tank as shown in Fig. It is a universal practice to use Buchholz relays on all such oil immersed transformers having ratings in excess of 750 kVA.

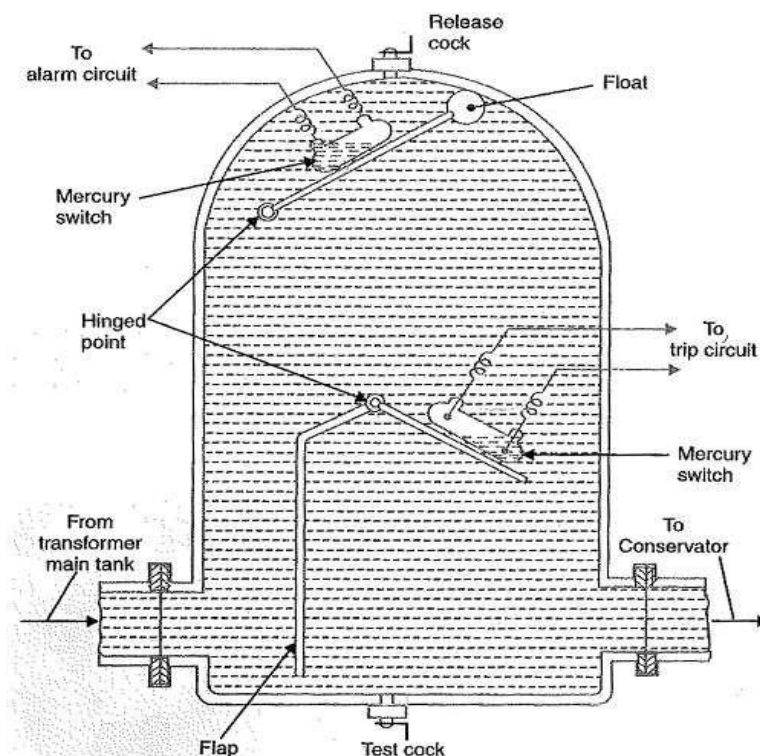

Fig:6.5 Buchholz relay

Construction:

The above Fig shows the constructional details of a Buchholz relay. It takes the form of a domed vessel placed in the connecting pipe between the main tank and the conservator. The device has two elements. The upper element consists of a mercury type switch attached to a float. The lower element contains a mercury switch mounted on a hinged type flap located in the direct path of the flow of oil from the transformer to the conservator. The upper element closes an alarm circuit during incipient faults whereas the lower element is arranged to trip the circuit breaker in case of severe internal faults.

Operation:

(i) In case of incipient faults within the transformer, the heat due to fault causes the decomposition of some transformer oil in the main tank. The products of decomposition contain more than 70% of hydrogen gas. The hydrogen gas being light tries to go into the conservator and in the process gets entrapped in the upper part of relay chamber. When a predetermined amount of gas gets accumulated, it exerts sufficient pressure on the float to cause it to tilt and close the contacts of mercury switch attached to it. This completes the alarm circuit to sound an alarm.

(ii) If a serious fault occurs in the transformer, an enormous amount of gas is generated in the main tank. The oil in the main tank rushes towards the conservator via the Buchholz relay and in doing so tilts the flap to close the contacts of mercury switch. This completes the trip circuit to open the circuit breaker controlling the transformer.

Advantages of Buchholz Relay:

- It is the simplest form of transformer protection.
- It detects the incipient faults at a stage much earlier than is possible with other forms of protection.

Disadvantages of Buchholz Relay:

- It can only be used with oil immersed transformers equipped with conservator tanks.
- The device can detect only faults below oil level in the transformer. Therefore, separate protection is needed for connecting cables.

BUSBAR PROTECTION:

Busbars and lines are important elements of electric power system and require the immediate attention of protection engineers for safeguards against the possible faults occurring on them. The methods used for the protection of generators and transformers can also be employed, with slight modifications, for the busbars and lines. The modifications are necessary to cope with the protection problems arising out of greater length of lines and a large number of circuits connected to a Busbar Protection. Although differential protection can be used it becomes too expensive for longer lines due to the greater length of pilot wires required. Fortunately, less expensive methods are available which are reasonably effective in providing protection for the busbars and lines. In this chapter, we shall focus our attention on the various methods of protection of busbars and lines.

Busbar Protection in the generating stations and sub-stations form important link between the incoming and outgoing circuits. If a fault occurs on a busbar, considerable damage and disruption of supply will occur unless some form of quick-acting automatic protection is provided to isolate the faulty busbar. The busbar zone, for the purpose of protection, includes not only the busbars themselves but also the isolating switches, circuit breakers and the associated connections. In the

event of fault on any section of the busbar, all the circuit equipment connected to that section must be tripped out to give complete isolation.

The standard of construction for Busbar Protection has been very high, with the result that bus faults are extremely rare. However, the possibility of damage and service interruption from even a rare bus fault is so great that more attention is now given to this form of protection. Improved relaying methods have been developed, reducing the possibility of incorrect operation.

The two most commonly used schemes for busbar protection are :

1. Differential Protection:

The basic method for busbar protection is the differential scheme in which currents entering and leaving the bus are totalised. During normal load condition, the sum of these currents is equal to zero. When a fault occurs, the fault current upsets the balance and produces a differential current to operate a relay.

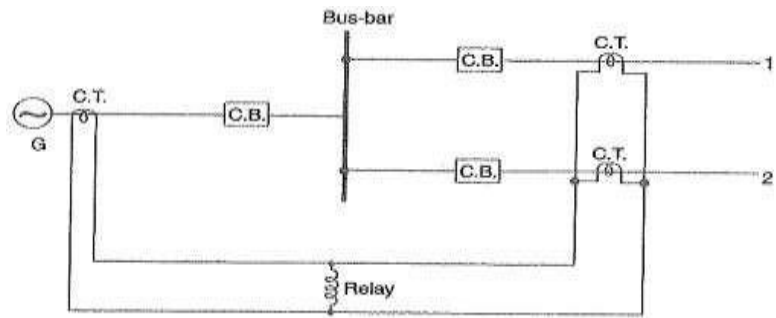

Fig-6.6

Fig.6.6 shows the single line diagram of current differential scheme for a station busbar. The Busbar Protection is fed by a generator and supplies load to two lines. The secondaries of current transformers in the generator lead, in line 1 and in line 2 are all connected in parallel. The protective relay is connected across this parallel connection. All CTs must be of the same ratio in the scheme regardless of the capacities of the various circuits. Under normal load conditions or external fault conditions, the sum of the currents entering the bus is equal to those leaving it and no current flows through the relay. If a fault occurs within the protected zone, the currents entering the bus will no longer be equal to those leaving it. The difference of these currents will flow through the relay and cause the opening of the generator, circuit breaker and each of the line circuit breakers.

2 Fault Bus Protection:

It is possible to design a station so that the faults that develop are mostly earth-faults. This can be achieved by providing earthed metal barrier (known as fault bus) surrounding each conductor throughout its entire length in the bus structure. With this arrangement, every fault that might occur must involve a connection between a conductor and an earthed metal. By directing the flow of earth-fault current, it is possible to detect the faults and determine their location. This type of protection is known as fault bus protection.

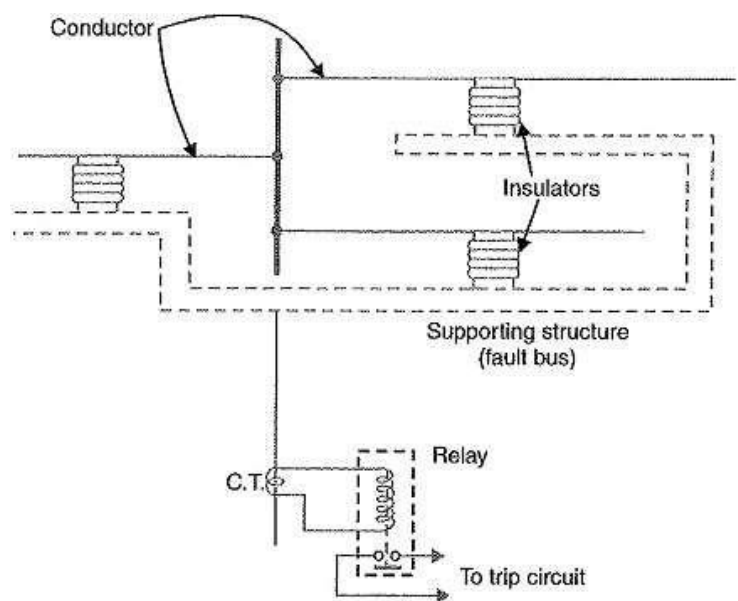

Fig-6.7

Fig.6.7 show the schematic arrangement of fault bus protection. The metal supporting structure or fault bus is earthed through a current transformer. A relay is connected across the secondary of this CT. Under normal operating conditions, there is no current flow from fault bus to ground and the relay remains inoperative. A fault involving a connection between a conductor and earthed supporting structure will result in current flow to ground through the fault bus, causing the relay to operate. The operation of relay will trip all breakers connecting equipment to the bus.

PROTECTION OF LINES:

The probability of faults occurring on the lines is much more due to their greater length and exposure to atmospheric conditions. This has called for many protective schemes which have no application to the comparatively simple cases of alternators and transformers. The requirements of line protection are :

- In the event of a short-circuit, the circuit breaker closest to the fault should open, all other circuit breakers remaining in a closed position.
- In case the nearest breaker to the fault fails to open, back-up protection should be provided by the adjacent circuit breakers.
- The relay operating time should be just as short as possible in order to preserve system stability, without unnecessary tripping of circuits.

The protection of lines presents a problem quite different from the protection of station apparatus such as generators, transformers and Busbar Protection. While differential protection is ideal method for lines, it is much more expensive to use. The two ends of a line may be several kilometers apart and to compare the two currents, a costly pilot-wire circuit is required. This expense may be justified but in general less costly methods are used. The common methods of line protection are :

- Time-graded overcurrent protection
- Differential protection
- Distance protection



Fig-6.8: shows the symbols indicating the various types of relay

1. DIFFERENTIAL PILOT WIRE PROTECTION:

The Differential Pilot Wire Protection is based on the principle that under normal conditions, the current entering one end of a line is equal to that leaving the other end. As soon as a fault occurs between the two ends, this condition no longer holds and the difference of incoming and outgoing currents is arranged to flow through a relay which operates the circuit breaker to isolate the faulty line. There are several Differential Pilot Wire Protection schemes in use for the lines. However, only the following two schemes will be discussed

a) Merz-Price Voltage Balance System:

Fig-6.9 shows the single line diagram of Merz-Price voltage balance system for the protection of a 3-phase line. Identical current transformers are placed in each phase at both ends of the line. The pair of CTs in each line is connected in series with a relay in such a way that under, normal conditions, their secondary voltages are equal and in opposition i.e. they balance each other.

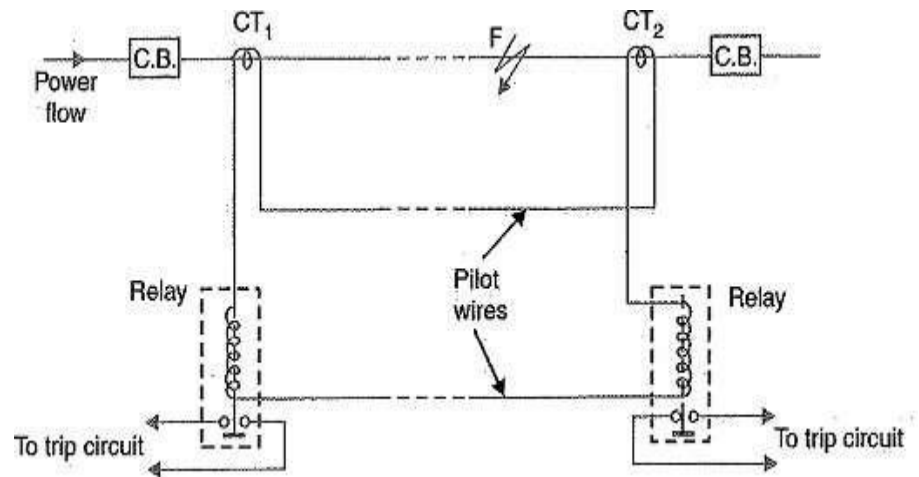

Fig-6.9

Under healthy conditions, current entering the line at one-end is equal to that leaving it at the other end.

Therefore, equal and opposite voltages are induced in the secondaries of the CTs at the two ends of the line. The result is that no current flows through the relays. Suppose a fault occurs at point F on the line as shown in Fig. This will cause a greater current to flow through CT₁ than through CT₂. Consequently, their secondary voltages become unequal and circulating current flows through the pilot wires and relays. The circuit breakers at both ends of the line will trip out and the faulty line will be isolated.

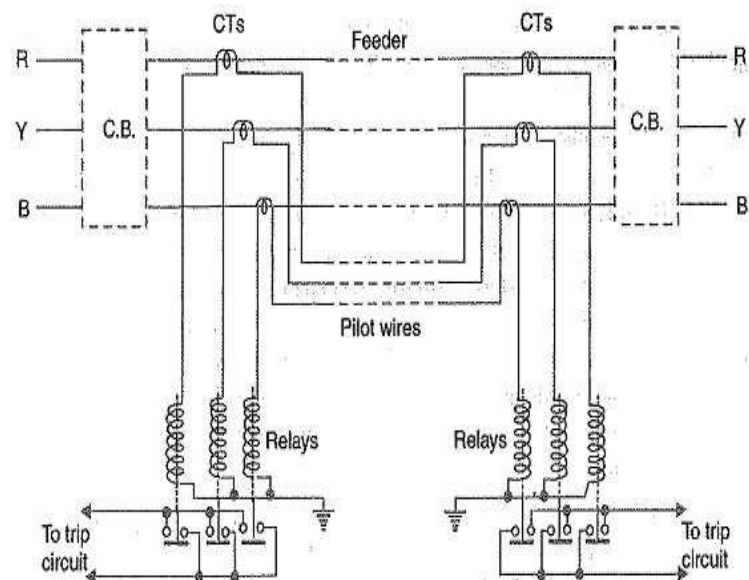

Fig-6.10

Fig-6.10 shows the connections of Merz-Price voltage balance scheme for all the three phases of the line.

Advantages of Differential Pilot Wire Protection:

- This system can be used for ring mains as well as parallel feeders,
- This system provides instantaneous protection for ground faults. This decreases the possibility of these faults involving other phases.
- This system provides instantaneous relaying which reduces the amount of damage to overhead conductors resulting from arcing faults.

Disadvantages of Differential Pilot Wire Protection:

- Accurate matching of current transformers is very essential.
- If there is a break in the pilot-wire circuit, the system will not operate.
- This system is very expensive owing to the greater length of pilot wires required.
- In case of long lines, charging current due to pilot-wire capacitance effects may be sufficient to cause relay operation even under normal conditions.
- This system cannot be used for line voltages beyond 33 kV because of constructional difficulties in matching the current transformers.

b) Translay scheme:

This system is similar to voltage balance system except that here balance or opposition is between the voltages induced in the secondary windings wound on the relay magnets and not between the secondary voltages of the line current transformers. This permits to use current transformers of normal design and eliminates one of the most serious limitations of original voltage balance system, namely ; its limitation to the system operating at voltages not exceeding 33 kV.

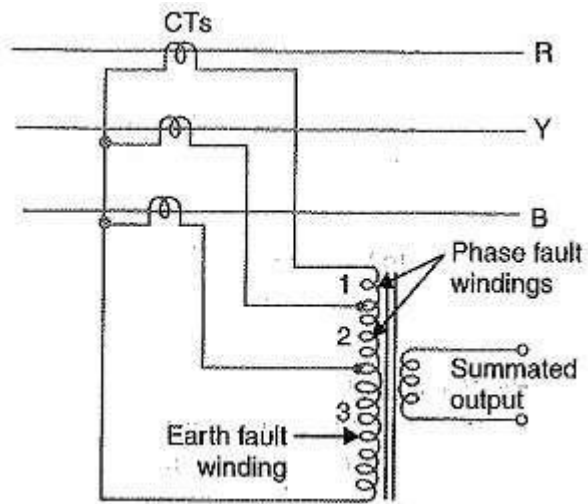

Fig-6.11

The application of Translay scheme for a single phase line has already been discussed. This can be extended to 3-phase system by applying one relay at each end of each phase of the 3-phase line. However, it is possible to make further simplification by combining currents derived from all phases in a single relay at each end, using the principle of summation transformer (See Fig-6.11). A summation transformer is a device that reproduces the poly phase line currents as a single-phase quantity. The three lines CTs are connected to the tapped primary of summation transformer. Each line CT energizes a different number of turns (from line to neutral) with a resulting single phase output. The use of summation transformer permits two advantages viz (i) primary windings 1 and 2 can be used for phase faults whereas winding 3 can be used for earth fault (ii) the number of pilot wires required is only two.

Schematic arrangement:

The Translay scheme for the protection of a 3-phase line is shown in Fig-6.12. The relays used in the scheme are essentially overcurrent induction type relays. Each relay has two electromagnetic elements. The upper element carries a winding (11 or 11 a) which is energized as a summation transformer from the secondaries of the line CTs connected in the phases of the line to be protected. The upper element also carries a secondary winding (12 or 12 a) which is connected in series with the operating winding (13 or 13 a) on the lower magnet. The secondary windings 12, 12 a and operating windings 13, 13 a are connected in series in such a way that voltages induced in them oppose each other. Note that relay discs and tripping circuits have been omitted in the diagram for clarity.

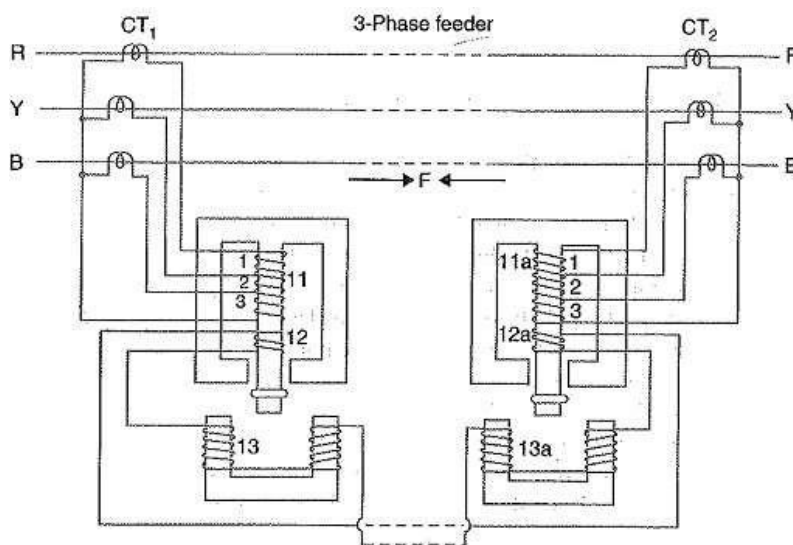

Fig-6.12

Operation:

When the feeder is sound, the currents at its two ends are equal so that the secondary currents in both sets of CTs are equal. Consequently, the currents flowing in the relay primary winding 11 and 11 a will be equal and they will induce equal voltages in the secondary windings 12 and 12a. Since these windings are connected in opposition, no current flows in them or in the operating windings 13 and 13a. In the event of a fault on the protected line, the line current at one end must carry a greater current than that at the other end. The result is that voltages induced in the secondary windings 12 and 12 a will be different and the current will flow through the operating coils 13, 13a and the pilot circuit. Under these conditions, both upper and lower elements of each relay are energised and a forward torque acts on the each relay disc. The operation of the relays will open the circuit breakers at both ends of the line.

- Suppose a fault F occurs between phases R and Y and is fed from both sides as shown in Fig. 11. This will energise only section 1 of primary windings 11 and 11a and induce voltages in the secondary windings 12 and 12a. As these voltages are now additive, therefore, current will circulate through operating coils 13, 13a and the pilot circuit. This will cause the relay contacts to close and open the circuit breakers at both ends. A fault between phases Y and B energises section 2 of primary windings 11 and 11a whereas that between R and B will energise the sections 1 and 2.
- Now imagine that an earth fault occurs on phase R. This will energise sections 1, 2 and 3 of the primary windings 11 and 11a. Again if fault is fed from both ends, the voltages induced in the secondary windings 12 and 12a are additive and cause a current to flow through the operating coils 13, 13a. The relays, therefore, operate to open the circuit breakers at both ends of the line. In the event of earth fault on phase Y, sections 2 and 3 of primary winding 11 and 11a will be energised and cause the relays to operate. An earth fault on phase B will energise only section 3 of relay primary windings 11 and 11a.

Advantages

- The system is economical as only two pilot wires are required for the protection of a 3-phase line.
- Current transformers of normal design can be used.
- The pilot wire capacitance currents do not affect the operation of relays.

2. DISTANCE PROTECTION:

Both time-graded and pilot-wire system are not suitable for the protection of very long high voltage transmission lines. The former gives an unduly long time delay in fault clearance at the generating station end when there are more than four or five sections and the pilot-wire system becomes too expensive owing to the greater length of pilot wires required. This has led to the development of Distance Protection in which the action of relay depends upon the distance (or impedance) between the point where the relay is installed and the point of fault. This system provides discrimination protection without employing pilot wires.

The principle and operation of Distance Protection relays have already been discussed here. We shall now consider its application for the protection of transmission lines. Fig-6.13.(i) shows a simple system consisting of lines in series such that power can flow only from left to right.

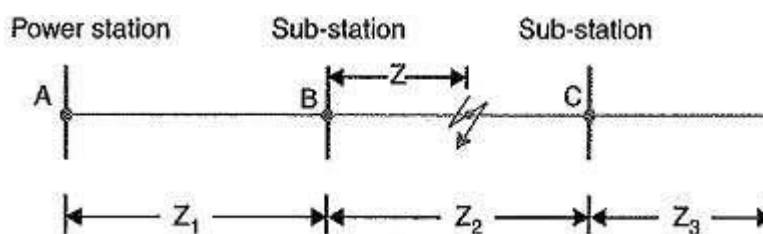

Fig-6.13(i)

The relays at A, B and C are set to operate for impedance less than Z_1 , Z_2 and Z_3 respectively. Suppose a fault occurs between sub-stations B and C, the fault impedance at power station and sub-station A and B will be $Z_1 + Z$ and Z respectively. It is clear that for the portion shown, only relay at B will operate. Similarly, if a fault occurs within section AB, then only relay at A will operate. In this manner, instantaneous protection can be obtained for all conditions of operation.

In actual practice, it is not possible to obtain instantaneous protection for complete length of the line due to inaccuracies in the relay elements and instrument transformers. Thus the relay at A [See Fig-6.13(i)] would not be

very reliable in distinguishing between a fault at 99% of the distance AB and the one at 101% of distance AB. This difficulty is

overcome by using 'three-zone' Distance Protection shown in Fig-6.13.(ii).

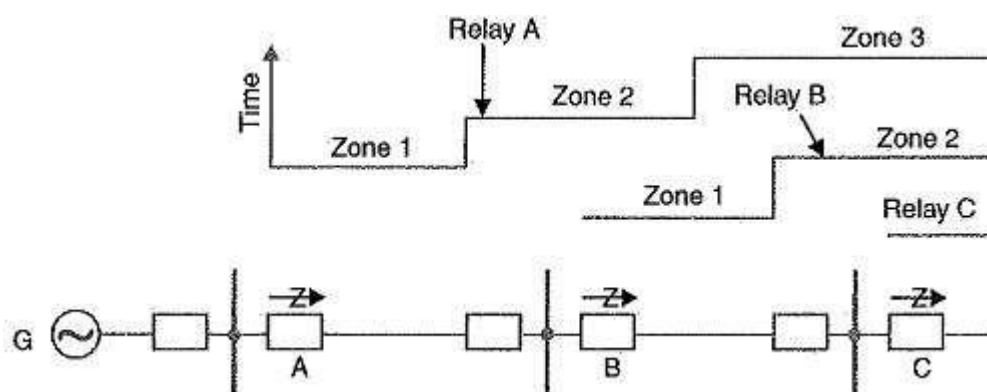

Fig-6.13(ii)

In this scheme of Distance Protection, three distance elements are used at each terminal. The zone 1 element covers first 90% of the line and is arranged to trip instantaneously for faults in this portion. The zone 2 element trips for faults in the remaining 10% of the line and for faults in the next line section, but a time delay is introduced to prevent the line from being tripped if the fault is in the next section. The zone 3 element provides back-up protection in the event a fault in the next section is not cleared by its breaker.

3. TIME GRADED OVERCURRENT PROTECTION:

In this scheme of Time Graded Overcurrent Protection, time discrimination is incorporated. In other words, the time setting of relays is so graded that in the event of fault, the smallest possible part of the system is isolated. We shall discuss a few important cases.

1. Radial feeder:

The main characteristic of a radial system is that power can flow only in one direction, from generator or supply end to the load. It has the disadvantage that continuity of supply cannot be maintained at the receiving end in the event of fault. Time Graded Overcurrent Protection protection of a radial feeder can be achieved by using

a) Definite time relays

Using definite time relays: Fig-6.14 shows the overcurrent protection of a radial feeder by definite time relays. The time of operation of each relay is fixed and is independent of the operating current. Thus relay D has an operating time of 0.5 second while for other relays, time delay is successively increased by 0.5 second. If a fault occurs in the section DE, it will be cleared in 0.5 second by the relay and circuit breaker at D because all other relays have higher operating time. In this way only section DE of the system will be isolated. If the relay at D fails to trip, the relay at C will operate after a time delay of 0.5 second i.e. after 1 second from the occurrence of fault.

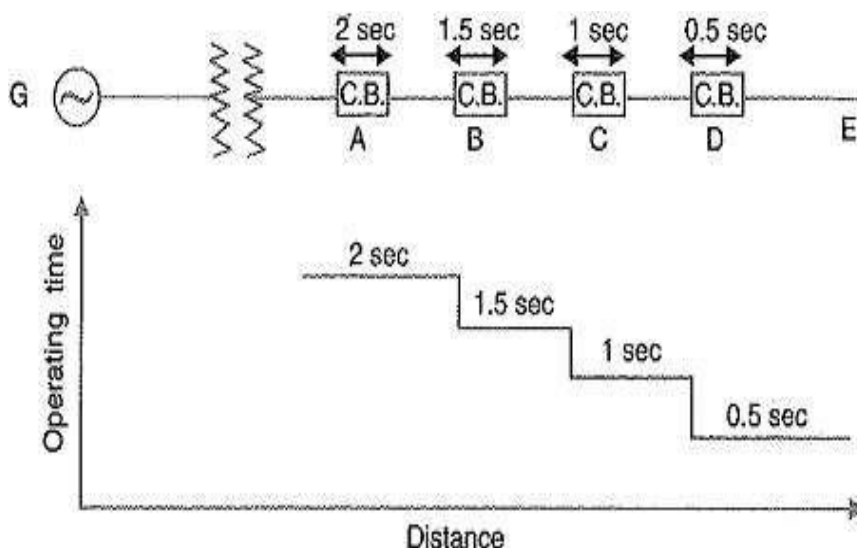

The disadvantage of this system is that if there are a number of feeders in series, the tripping time for faults near the supply end becomes high (2 seconds in this case). However, in most cases, it is necessary to limit the maximum tripping time to 2 seconds. This disadvantage can be overcome to a reasonable extent by using inverse-time relays

Fig-6.14

b) Inverse Time Relays:

Fig-6.15 shows overcurrent protection of a radial feeder using inverse time relays in which operating time is inversely proportional to this arrangement, the farther the circuit breaker from the generating operating time.

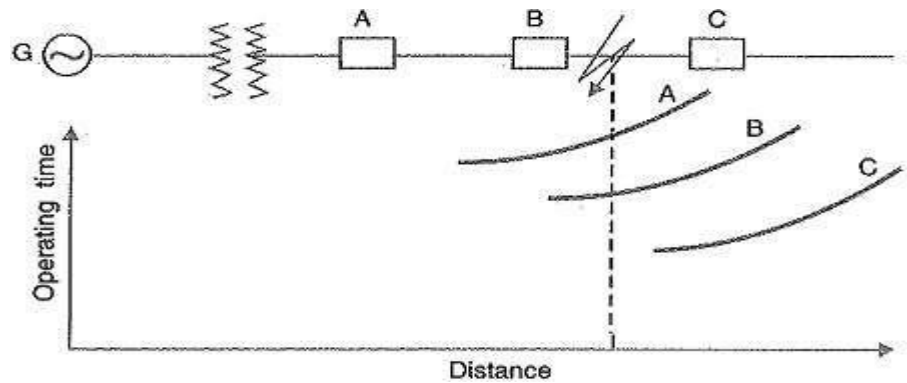

Fig 6.15

The three relays at A, B and C are assumed to have inverse-time characteristics. A fault in section BC will give relay times which will allow breaker at B to trip out before the breaker at A.

2. Parallel feeders:

Where continuity of supply is particularly necessary, two parallel feeders may be installed. If a fault occurs on one feeder, it can be disconnected from the system and continuity of supply can be maintained from the other feeder. The parallel feeders cannot be protected by non-directional overcurrent relays only. It is necessary to use directional relays also and to grade the time setting of relays for selective trippings.

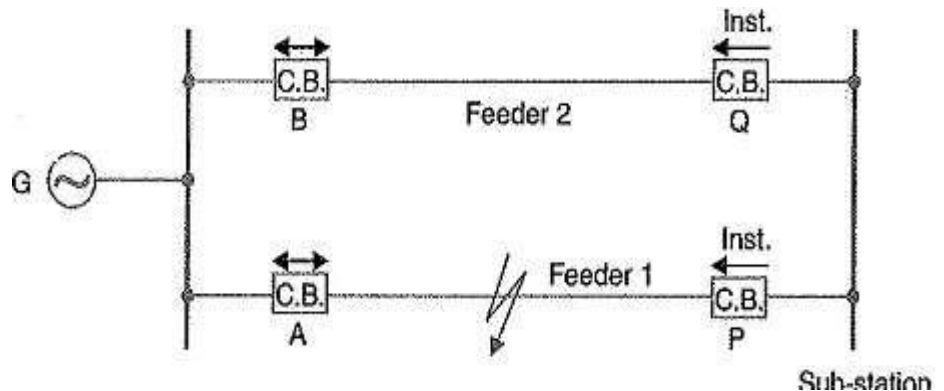

Fig-6.16

Fig-6.16 shows the system where two feeders are connected in parallel between the generating station and the sub-station. The protection of this system requires that

- each feeder has a non-directional overcurrent relay at the generator end. These relays should have inverse-time characteristic.
- each feeder has a reverse power or directional relay at the sub-station end. These relays should be instantaneous type and operate only when power flows in the reverse direction e. in the direction of arrow at P and Q.

Suppose an earth fault occurs on feeder 1 as shown in Fig-6.16. It is desired that only circuit breakers at A and P should open to clear the fault whereas feeder 2 should remain intact to maintain the continuity of supply. In fact, the above arrangement accomplishes this job. The shown fault is fed via two routes, viz.

- Directly from feeder 1 via the relay A
- From feeder 2 via B, Q, sub-station and P

Therefore, power flow in relay Q will be in normal direction but is reversed in the relay P. This causes the opening of circuit breaker at P. Also the relay A will operate while relay B remains inoperative. It is

because these relays have inverse-time characteristics and current flowing in relay A is in excess of that flowing in relay B. In this way only the faulty feeder is isolated.

3. Ring main system:

In this system, various power stations or sub-stations are interconnected by alternate routes, thus forming a closed ring. In case of damage to any section of the ring, that section may be disconnected for repairs, and power will be supplied from both ends of the ring, thereby maintaining continuity of supply.

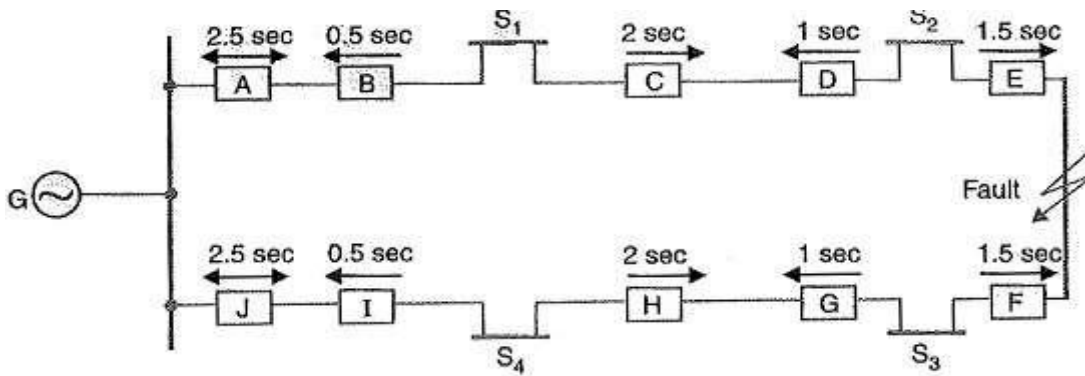

Fig-6.17

Fig-6.17 shows the single line diagram of a typical ring main system consisting of one generator G supplying four sub-stations S_1 , S_2 , S_3 and S_4 . In this arrangement, power can flow in both directions under fault conditions. Therefore, it is necessary to grade in both directions round the ring and also to use directional relays. In order that only faulty section of the ring is isolated under fault conditions, the types of relays and their time settings should be as follows :

- The two lines leaving the generating station should be equipped with non-directional overcurrent relays (relays at A and J in this case).
- At each sub-station, reverse power or directional relays should be placed in both incoming and outgoing lines (relays at B, C, D, E, F, G, H and I in this case).
- There should be proper relative time-setting of the relays. As an example, going round the loop $G S_1 S_2 S_3 S_4 G$; the outgoing relays (viz at A, C, E, G and I) are set with decreasing time limits e.g.

Similarly, going round the loop in the opposite direction (i.e. along $G S_1 S_2 S_3 S_4 G$), the outgoing relays (J, H, F, D and B) are also set with a decreasing time limit e.g.

Suppose a short circuit occurs at the point as shown in Fig. In order to ensure selectivity, it is desired that only circuit breakers at E and F should open to clear the fault whereas other sections of the ring should be intact to maintain continuity of supply. In fact, the above arrangement accomplishes this job. The power will be fed to the fault via two routes viz (i) from G around S_1 and S_2 and (ii) from G around S_4 and S_3 . It is clear that relays at A, B, C and D as well as J, I, H and G will not trip. Therefore, only relays at E and F will operate before any other relay operates because of their lower time-setting.

Chapter VII

Protection against Overvoltage and Lightning

Voltage Surge or Transient Voltage:

A sudden rise in voltage for a very short duration on the power system is known as a Voltage Surge or Transient Voltage.

Transients or surges are of temporary nature and exist for a very short duration (a few hundred μs) but they cause over Voltage Surge on the power system. They originate from switching and from other causes but by far the most important transients are those caused by lightning striking a transmission line. When lightning strikes a line, the surge rushes along the line, just as a flood of water rushes along a narrow valley when the retaining wall of a reservoir at its head suddenly gives way. In most of the cases, such surges may cause the line insulators (near the point where lightning has struck) to flash over and may also damage the nearby transformers, generators or other equipment connected to the line if the equipment is not suitably protected.

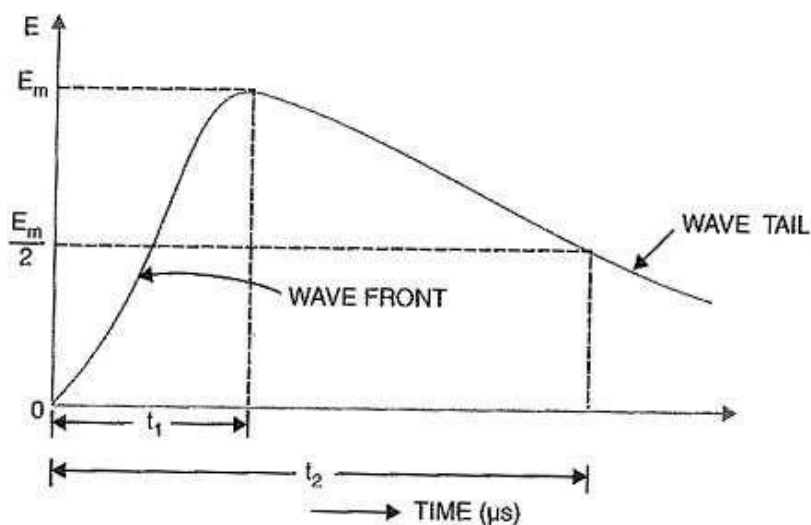

Fig-7.1

Fig-7.1 shows the wave-form of a typical lightning surge. The voltage build-up is taken along y-axis and the time along x-axis. It may be seen that lightning introduces a steep-fronted wave. The steeper the wave front, the more rapid is the build-up of voltage at any point in the network. In most of the cases, this build-up is comparatively rapid, being of the order of 1-5 μs . Voltage Surge are generally specified in terms of rise time t_1 and the time t_2 to decay to half of the peak value. For example, a 1/50 μs surge is one which reaches its maximum value in 1 μs and decays to half of its peak value is 50 μs .

CAUSES OF OVERVOLTAGES:

The overvoltages on a power system may be broadly divided into two main categories viz.

1. Internal causes
 - I. Switching surges
 - II. Insulation failure
 - III. Arcing ground
 - IV. Resonance
2. External causes
 - a) Lightning

Internal causes hardly increase the system voltage to twice the normal value. Generally, surges due to internal causes are taken care of by providing proper insulation to the equipment in the power system. However, surges due to lightning are very severe and may increase the system voltage to several times the normal value. If the equipment in the power system is not protected against lightning surges, these surges may cause considerable damage. In fact, in a power system, the protective devices provided against over voltages mainly take care of lightning surges.

Internal Causes of Overvoltages:

Internal causes of over voltages on the power system are primarily due to oscillations set up by the sudden changes in the circuit conditions. This circuit change may be a normal switching operation such as opening of a circuit breaker, or it may be the fault condition such as grounding of a line conductor. In practice, the normal system insulation is suitably designed to withstand such surges. We shall briefly discuss the internal causes of over voltages.

1. Switching Surges:

The overvoltages produced on the power system due to switching operations are known as switching surges.

- (i) Case of an open line: During switching operations of an unloaded line, travelling waves are set up which produce overvoltages on the line. As an illustration, consider an unloaded line being connected to a voltage source as shown in Fig-7.2.

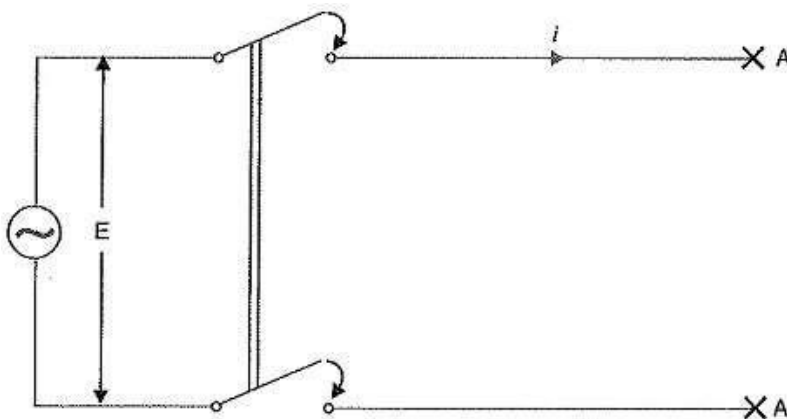

Fig-7.2

When the unloaded line is connected to the voltage source, a voltage wave is set up which travels along the line. On reaching the terminal point A, it is reflected back to the supply end without change of sign. This causes voltage doubling i.e. voltage on the line becomes twice the normal value. If $E_{r.m.s.}$ is the supply Voltage Surge, then instantaneous voltage which the line will have to withstand will be $2\sqrt{2} E$. This overvoltage is of temporary nature. It is because the line losses attenuate the wave and in a very short time, the line settles down to its normal supply voltage E . Similarly, if an unloaded line is switched off the line will attain a voltage of $2\sqrt{2} E$ for a moment before settling down to the normal value.

(ii) Case of a loaded line: Overvoltages will also be produced during the switching operations of a loaded line. Suppose a loaded line is suddenly interrupted. This will set up a voltage of $2 Z_n i$ across the break (i.e. switch) where i is the instantaneous value of current at the time of opening of line and Z_n is the natural impedance of the line. For example, suppose the line having $Z_n=1000\Omega$ carries a current of 100 A (r.m.s.) and the break occurs at the moment when current is maximum. The voltage across the breaker (i.e. switch) = $2 \sqrt{2} \times 100 \times 1000/1000 = 282.8$ kV. If V_m is the peak value of voltage in kV, the maximum voltage to which the line may be subjected is = $(V_m + 282.8)$ kV.

(iii) Current chopping: Current chopping results in the production of high voltage transients across the contacts of the air blast circuit breaker. It is briefly discussed. Unlike oil circuit breakers, which are independent for the effectiveness on the magnitude of the current being interrupted, air-blast circuit breakers retain the same extinguishing power irrespective of the magnitude of this current. When breaking low currents (e.g. transformer magnetizing current) with air-blast breaker, the powerful de-ionizing effect of air-blast causes the current to fall abruptly to zero well before the natural current zero is reached. This phenomenon is called current chopping and produces high transient voltage across the breaker contacts. Overvoltages due to current chopping are prevented by resistance switching.

2. Insulation failure:

The most common case of insulation failure in a power system is the grounding of conductor (i.e. insulation failure between line and earth) which may cause overvoltages in the system. This is illustrated in Fig-7.3.

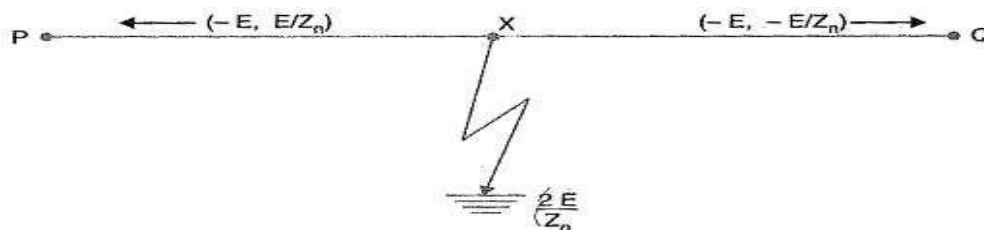

Fig-7.3

Suppose a line at potential E is earthed at point X . The earthing of the line causes two, equal voltages of $-E$ to travel along XQ and XP , containing currents $-E/Z_n$ and $+E/Z_n$ respectively. Both these currents pass through X to earth so that current to earth is $2 E/Z_n$.

3. Arcing ground:

In the early days of transmission, the neutral of three phase lines was not earthed to gain two advantages. Firstly, in case of line-to-ground fault, the line is not put out of Secondly, the zero sequence currents are eliminated, resulting in the decrease of interference with communication lines.

Insulated neutrals give no problem with short lines and comparatively low Voltage Surge. However, when the lines are long and operate at high voltages, serious problem called arcing ground is often witnessed. The arcing ground produces severe oscillations of three to four times the normal voltage.

The phenomenon of intermittent arc taking place in line-to-ground fault of a 3Φ system with consequent production of transients is known as arcing ground.

The transients produced due to arcing ground are cumulative and may cause serious damage to the equipment in the power system by causing breakdown of insulation. Arcing ground can be prevented by earthing the neutral.

4. Resonance:

Resonance in an electrical system occurs when inductive reactance of the circuit becomes equal to capacitive reactance. Under resonance, the impedance of the circuit is equal to resistance of the circuit and the p.f. is unity. Resonance causes high voltages in the electrical system. In the usual transmission lines, the capacitance is very small so that resonance rarely occurs at the fundamental supply frequency. However, if generator e.m.f. wave is distorted, the trouble of resonance may occur due to 5th or higher harmonics and in case of underground cables too.

LIGHTNING:

An electric discharge between cloud and earth, between clouds or between the charge centres of the same cloud is known as lightning.

Lightning is a huge spark and takes place when clouds are charged to such a high potential (+ve or -ve) with respect to earth or a neighbouring cloud that the dielectric strength of neighbouring medium (air) is destroyed. There are several theories which exist to explain how the cloud to be charge. The most accepted one is that during the uprush of warm moist air from earth between the air and the tiny particles of water causes the building up of charges. When drops of water are formed, the larger drops become positively charged and the smaller drops become negatively charged.

When the drops of water accumulate, they form clouds, and hence cloud may possess either a positive or a negative charge, depending upon the charge of drops of water they contain. The charge on a cloud may become so great that it may discharge to another cloud or to earth and we call this discharge as lightning.

The thunder which accompanies lightning is due to the fact that lightning suddenly heats up the air, thereby causing it to expand. The surrounding air pushes the expanded air back and forth causing the wave motion of air which we recognise as thunder.

Mechanism of Lightning Discharge:

Let us now discuss the manner in which a lightning discharge occurs. When a charged cloud passes over the earth, it induces equal and opposite charge on the earth below. Fig.shows a negatively charged cloud inducing a positive charge on the earth below it. As the charge acquired by the cloud increases, the potential between cloud and earth increases and, therefore, gradient in the air increases. When the potential gradient is sufficient (5 kV/cm to 10 kV/cm) to break down the surrounding air, the lightning stroke starts. The stroke mechanism is as under :

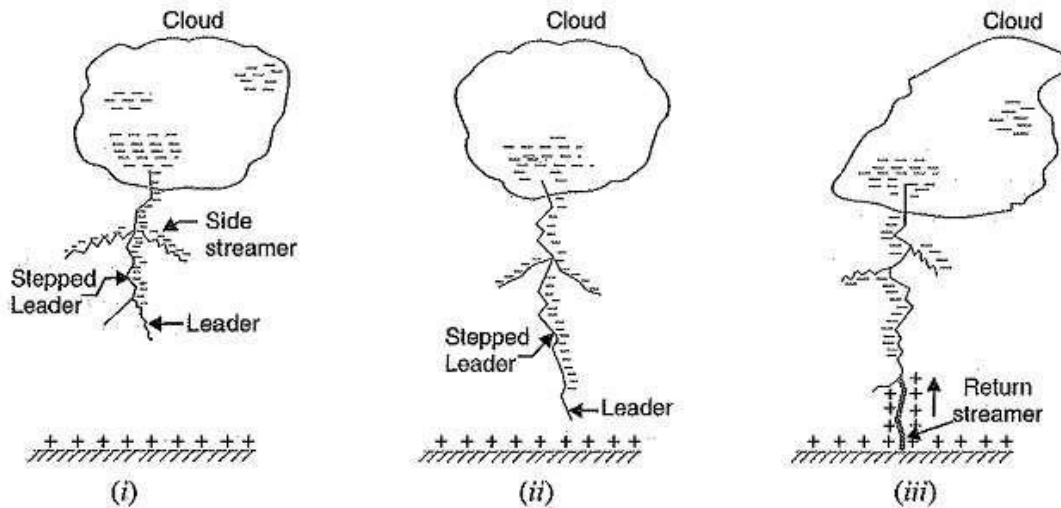

Fig-7.4

(i) As soon as the air near the cloud breaks down, a streamer called leader streamer or pilot streamer starts from the cloud towards the earth and carries charge with it as shown in Fig-7.4.(i). The leader streamer will continue its journey towards earth as long as the cloud, from which it originates feeds enough charge to it to maintain gradient at the tip of leader streamer above the strength of air. If this gradient is not maintained, the leader streamer stops and the charge is dissipated without the formation of a complete stroke.

In other words, the leader streamer will not reach the earth. Fig-7.4(i) shows the leader streamer being unable to reach the earth as gradient at its end cloud not be maintained above the strength of air. It may be noted that current in the leader streamer is low (<100 A) and its velocity of propagation is about 0.05% that of velocity of light. Moreover, the luminosity of leader is also very low.

(ii) The path of leader streamer is a path of ionisation and, therefore, of complete breakdown of insulation. As the leader streamer reaches near the earth, a return streamer shoots up from the earth [See Fig-7.4 (iii)] to the cloud, following the same path as the main channel of the downward leader.

The action can be compared with the closing of a switch between the positive and negative terminals; the downward leader having negative charge and return streamer the positive charge. This phenomenon causes a sudden spark which we call lightning. With the resulting neutralization of much of the negative charge on the cloud, any further discharge from the cloud may have to originate from some other portion of it.

The following points may be noted about lightning discharge :

- A lightning discharge which usually appears to the eye as a single flash is in reality made up of a number of separate strokes that travel down the same path. The interval between them varies from 0.0005 to 0.5 second. Each separate stroke starts as a downward leader from the cloud.
- It has been found that 87% of all lightning strokes result from negatively charged clouds and only 13% originate from positively charged clouds,
- It has been estimated that throughout the world, there occur about 100 lightning strokes per
- Lightning discharge may have currents in the range of 10 kA to 90 kA.

Types of Lightning Strikes:

There are two Types of Lightning Strikes may strike the power system (e.g. overhead lines, towers, sub-stations etc.), namely;

1. Direct stroke: In the direct stroke, the lightning discharge (i.e. current path) is directly from the cloud to the subject equipment e.g. an overhead line. From the line, the current path may be over the insulators down the pole to the ground. The overvoltages set up due to the stroke. may be large enough to flashover this path directly to the ground. The direct strokes can be of two types viz.

(i) Stroke A and (ii) stroke B.

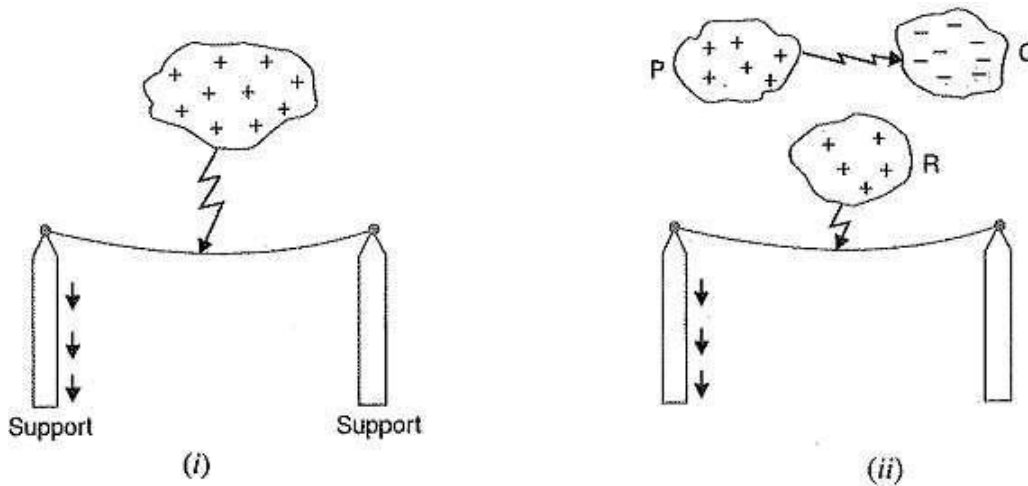

Fig-7.5

- (i) In stroke A, the lightning discharge is from the cloud to the subject equipment i.e. an overhead line in this case as shown in Fig-7.5.(i). The cloud will induce a charge of opposite sign on the tall object (e.g. an overhead line in this case). When the potential between the cloud and line exceeds the breakdown value of air, the lightning discharge occurs between the cloud and the line.
- (ii) (ii) In stroke B, the lightning discharge occurs on the overhead line as a result of stroke A between the clouds as shown in Fig-7.5.(ii). There are three clouds P, Q and R having positive, negative and positive charges respectively. The charge on the cloud Q is bound by the cloud R. If the cloud P shifts too near the cloud Q, then lightning discharge will occur between them and charges on both these clouds disappear quickly. The result is that charge on cloud R suddenly becomes free and it then discharges rapidly to earth, ignoring tall objects.
- (iii) Two points are worth noting about direct strokes. Firstly, direct strokes on the power system are very rare. Secondly, stroke A will always occur on tall objects and hence protection can be provided against it. However, stroke B completely ignores the height of the object and can even strike the ground. Therefore, it is not possible to provide protection against stroke B.

2. Indirect stroke: Indirect strokes result from the electrostatically induced charges on the conductors due to the presence of charged clouds. This is illustrated in Fig-7.6. A positively charged cloud is above the line and induces a negative charge on the line by electrostatic induction. This negative charge, however, will be only on that portion of the line right under the cloud and the portions of the line away from it will be positively charged as shown in Fig. The induced positive charge leaks slowly to earth via the insulators. When the cloud discharges to earth or to another cloud, the negative charge on the wire is isolated as it cannot flow quickly to earth over the insulators. The result is that negative charge rushes along the line in both directions in the form of travelling waves. It may be worthwhile to mention here that majority of the surges in a transmission line are caused by indirect Types of Lightning Strikes strokes.

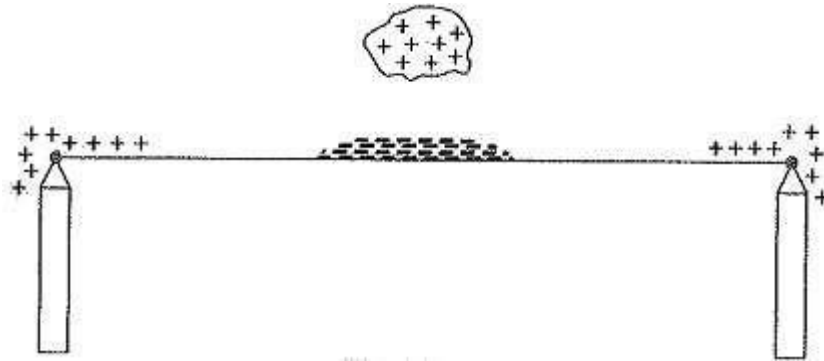

Fig-7.6

HARMFUL EFFECTS OF TYPES OF LIGHTNING STRIKES:

A direct or indirect lightning stroke on a transmission line produces a steep-fronted voltage wave on the line. The voltage of this wave may rise from zero to peak value (perhaps 2000 kV) in about $1 \mu\text{s}$ and decay to half the peak value in about $5 \mu\text{s}$. Such a steep-fronted voltage wave will initiate travelling waves along the line in both directions with the velocity dependent upon the L and C parameters of the line.

(i) The travelling waves produced due to lightning surges will shatter the insulators and may even wreck poles.

(ii) If the travelling waves produced due to Types of Lightning Strikes hit the windings of a transformer or generator, it may cause considerable damage. The inductance of the windings opposes any sudden passage of electric charge through it. Therefore, the electric charges "pile up" against the transformer (or generator). This induces such an excessive pressure between the windings that insulation may breakdown, resulting in the production of arc. While the normal voltage between the terminals is never enough to start an arc, once the insulation has broken down and an arc has been started by a momentary overvoltage, the line voltage is usually sufficient to maintain the arc long enough to severely damage the machine.

If the arc is initiated in any part of the power system by the lightning stroke, this arc will set up very disturbing oscillations in the line. This may damage other equipment connected to the line

PROTECTION AGAINST LIGHTNING:

Transients or surges on the power system may originate from switching and from other causes but the most important and dangerous surges are those caused by lightning. The lightning surges may cause serious damage to the expensive equipment in the power system (e.g. generators, transformers etc.) either by direct strokes on the equipment or by strokes on the transmission lines that reach the equipment as travelling waves. It is necessary to provide protection against both kinds of surges. The most commonly used devices for protection against lightning surges are :

- Earthing screen
- Overhead ground wires
- Lightning arresters or surge diverters

Earthing screen provides protection to power stations and sub-stations against direct strokes whereas overhead ground wires protect the transmission lines against direct lightning strokes. Flow-ever; lightning arresters or surge diverters protect the station apparatus against both direct strokes and the strokes that come into the apparatus as travelling waves. We shall briefly discuss these methods of protection.

The Earthing Screen:

The power stations and sub-stations generally house expensive equipment. These stations can be protected against direct lightning strokes by providing earthing screen. It consists of a network of copper conductors (generally called shield or screen) mounted all over the electrical equipment in the sub-station or power station. The shield is properly connected to earth on at least two points through a low impedance. On the occurrence of direct stroke on the station, screen provides a low resistance path by which lightning surges are conducted to ground. In this way, station equipment is protected against damage. The limitation of this method is that it does not provide protection against the travelling waves which may reach the equipment in the station.

Overhead ground wires:

The most effective method of providing protection to transmission lines against direct lightning strokes is by the use of overhead ground wires as shown in Fig-7.7. For simplicity, one ground wire and one line conductor are shown. The ground wires are placed above the line conductors at such positions that practically all lightning strokes are intercepted by them e. ground wires). The ground wires are grounded at each tower or pole through as low resistance as possible. Due to their proper location, the ground wires will take up all the lightning strokes instead of allowing them to line conductors.

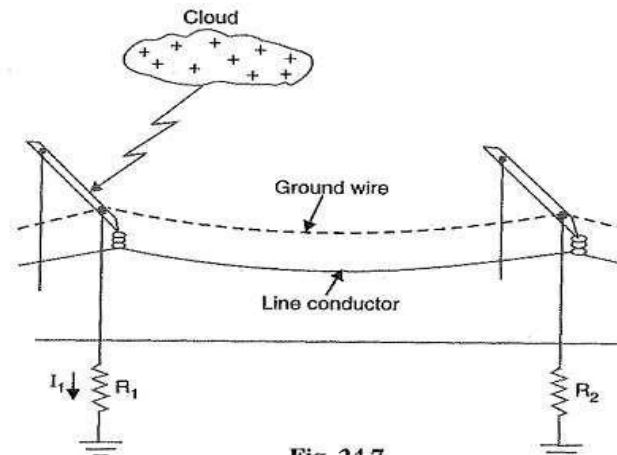

Fig-7.7

When the direct lightning stroke occurs on the transmission line, it will be taken up by the ground wires. The heavy lightning current (10 kA to 50 kA) from the ground wire flows to the ground, thus protecting the line from the harmful effects of Types of Lightning Strikes. It may be mentioned here that the degree of protection provided by the ground wires depends upon the footing resistance of the tower. Suppose, for example, tower-footing resistance is R_1 ohms and that the lightning current from tower to ground is I_1 amperes. Then the tower rises to a potential V_t given by ;

Since $V_t (= I_1 R_1)$ is the approximate voltage between tower and line conductor, this is also the voltage that will appear across the string of insulators. If the value of V_t is less than that required to cause insulator flashover, no trouble results. On the other hand, if V_t is excessive, the insulator flashover may occur. Since the value of V_t depends upon tower-footing resistance R_1 , the value of this resistance must be kept as low as possible to avoid insulator flashover.

Advantages

- It provides considerable protection against direct lightning strokes on transmission lines.
- A grounding wire provides damping effect on any disturbance travelling along the line as it acts as a short-circuited secondary.
- It provides a certain amount of electrostatic shielding against external fields. Thus it reduces the voltages induced in the line conductors due to the discharge of a neighbouring cloud.

Disadvantages

- It requires additional cost.
- There is a possibility of its breaking and falling across the line conductors, thereby causing a short-circuit fault. This objection has been greatly eliminated by using galvanised stranded steel conductors as ground wires. This provides sufficient strength to the ground wires

LIGHTNING ARRESTER

Definition: The device which is used for the protection of the equipment at the substations against travelling waves, such type of device is called lightning arrester or surge diverter. In other words, lightning arrester diverts the abnormal high voltage to the ground without affecting the continuity of supply. It is connected between the line and earth, i.e., in parallel with the equipment to be protected at the substation.

The following are the damages that are caused by the travelling wave on the substation equipment.

1. The high peak or crest voltage of the surge may cause flash-over in the internal winding thereby spoil the winding insulation.
2. The steep wave fronts of the surges may cause external flashover between the terminal of the transformer.
3. The highest peak voltage of the surge may cause external flashover, between the terminal of the electrical equipment which may result in damage to the insulator.

Working of Lightning Arrester

When a travelling wave reaches the arrester, it sparks over at a certain prefixed voltage as shown in the figure below. The arrester provides a conducting path to the waves of relatively low impedance between the line and the ground. The surge impedance of the line restricts the amplitude of current flowing to ground.

The lightning arrester provides a path of low impedance only when the travelling surge reaches the surge diverter, neither before it nor after it. The insulation of the equipment can be protected if the shape of the voltage and current at the diverter terminal is similar to the shape shown below.

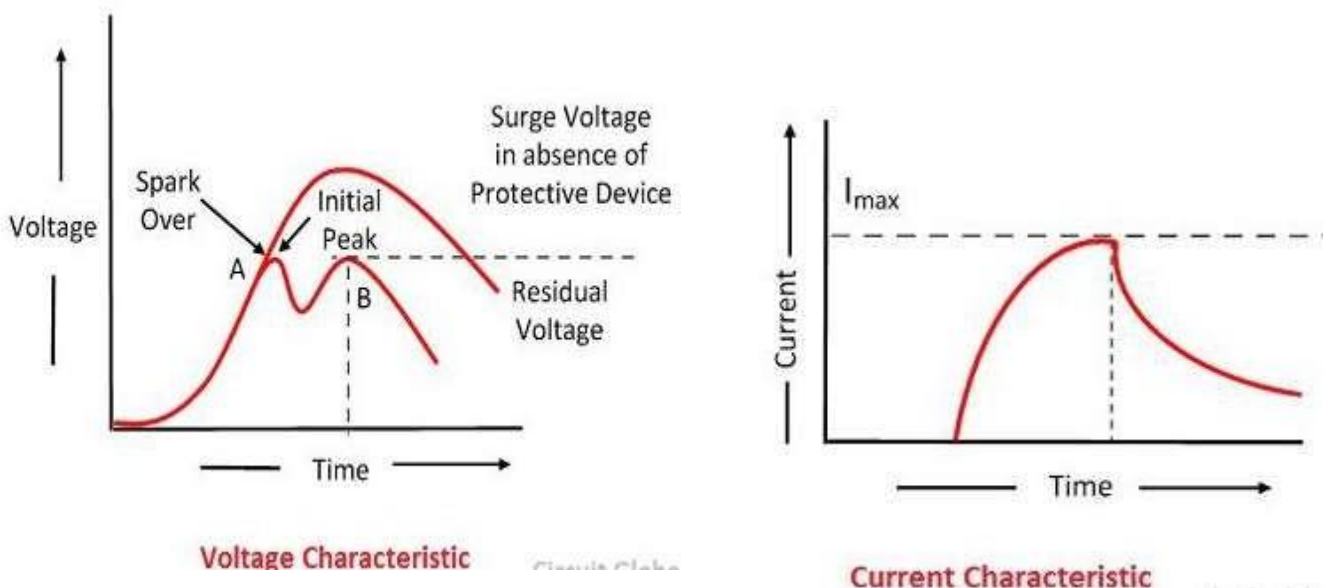

An ideal lightning arrester should have the following characteristics;

1. It should not draw any current during normal operating condition, i.e., it sparks-over voltage must be above the normal or abnormal power frequency that may occur in the system.
2. Any transient abnormal voltage above the breakdown value must cause it to break down as quickly as possible so that it may provide a conducting path to ground.
3. When the breakdown has taken place, it should be capable of carrying the resulting discharge current without getting damaged itself and without the voltage across it exceeding the breakdown value.
4. The power frequency current following the breakdown must be interrupted as soon as the transient voltage has fallen below the breakdown value.

There are many types of lightning arrester which are used to protect the power system. The choices of the lightning arrester depend on the factor like, voltage and frequency of the line, cost, weather condition and reliability.

Location of Lightning Arrester

The lightning arrester is located close to the equipment that is to be protected. They are usually connected between phase and ground in an AC system and pole and ground in case of the DC system. In an AC system, separate arrester is provided for each phase.

In an extra-high voltage AC system the surge diverter is used to protect the generators, transformers, bus bars, lines, circuit breakers, etc. In HVDC system the arrester is used to protect the buses, valves converter units reactors, filter, etc.

TYPES OF LIGHTNING ARRESTERS

The lightning arrester protects the electrical equipment from lightning. It is placed very near to the equipment and when the lightning occurs the arrester diverts the high voltage wave of lightning to the ground. The selection of arrester depends on the various factors like voltage, current, reliability, etc. The lightning arrester is mainly classified into some different types. These types are;

1. Rod Gap Arrester

It is one of the simplest forms of the arrester. In such type of arrester, there is an air gap between the ends of two rods. The one end of the arrester is connected to the line and the second end of the rod is connected to the ground. The gap setting of the arrester should be such that it should break before the damage. When the high voltage occurs on the line, the gap sparks and the fault current passes to the earth. Hence the equipment is protected from damage.

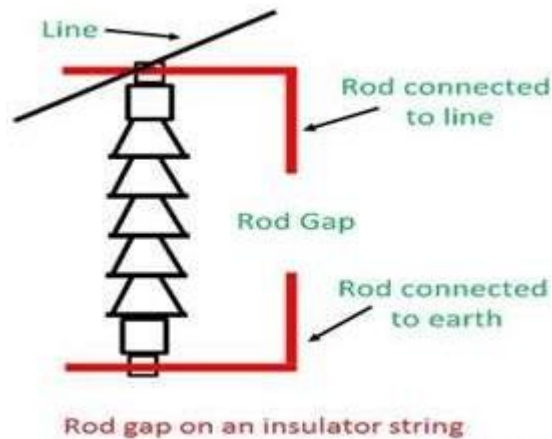

The difficulty with the rod arrester is that once the spark having taken place it may continue for some time even at low voltages. To avoid it a current limiting reactor in series with the rod is used. The resistance limits the current to such an extent that it is sufficient to maintain the arc. Another difficulty with the rod gap is that the rod gap is liable to be damaged due to the high temperature of the arc which may cause the rod to melt.

Limitations

- After the surge is over, the arc in the gap is maintained by the $\sqrt{}$ normal supply voltage, leading to a short-circuit on the system.
- The rods may melt or get damaged due to excessive heat produced by the arc.
- The climatic conditions (e.g. rain, humidity, temperature etc.) affect the performance of rod gap arrester.
- The polarity of the surge also affects the performance of this arrester.

2. HornGapArrester

It consists of two horns shaded piece of metal separated by a small air gap and connected in shunt between each conductor and earth. The distance between the two electrodes is such that the normal voltage between the line and earth is insufficient to jump the gap. But the abnormal high voltage will break the gap and so find a path to earth.

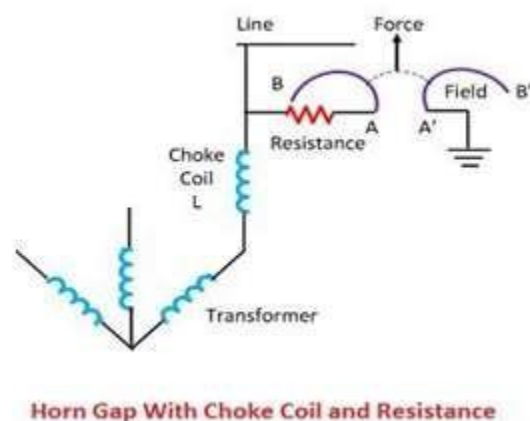

Advantages

- The arc is self-clearing. Therefore, this type of arrester does not cause short-circuiting of the system after the surge is over as in the case of rod gap.
- Series resistance helps in limiting the follow current to a small value.

Limitations

- The bridging of gap by some external agency (e.g. birds) can render the device useless.
- The setting of horn gap is likely to change due to corrosion or pitting. This adversely affects the performance of the arrester.
- The time of operation is comparatively long, say about 3 seconds. In view of the very short operating time of modern protective gear for feeders, this time is far long.

3. Expulsion Type Lightning Arrester

Expulsion type arrester is an improvement over the rod gap in that it seals the flow of power frequency follows the current. This arrester consists of a tube made up of fibre which is very effective, isolating spark gap and an interrupting spark gap inside the fibre tube.

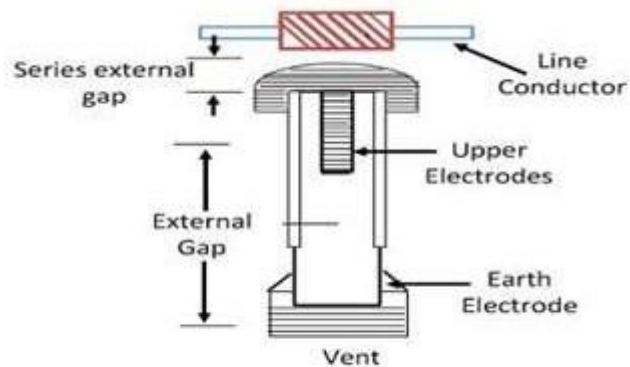

Expulsion-type Surge Diverter

During operation, the arc due to the impulse spark over inside the fibrous tube causes some fibrous material of the tube to volatile in the form of the gas, which is expelled through a vent from the bottom of the tube. Thus, extinguishing the arc just like in circuit breakers.

Advantages

- They are not very expensive.
- They are improved form of rod gap arresters as they block the flow of power frequency follow currents,
- They can be easily installed.

Limitations

- An expulsion type arrester can perform only limited number of operations as during each operation some of the fibre material is used up.
- This type of arrester cannot be mounted in an enclosed equipment due to the discharge of gases during operation.
- Due to the poor volt/amp characteristic of the arrester, is not suitable for the protection of expensive equipment.

4. Valve Type Lightning Arrester

Such type of resistor is called nonlinear diverter. It essentially consists a divided spark gap in series with a resistance element having the nonlinear characteristic.

The divided spark gap consists of some identical elements coupled in series. Each of them consists two electrodes with the pre-ionization device. Between each element, a grading resistor of high ohmic value is connected in parallel.

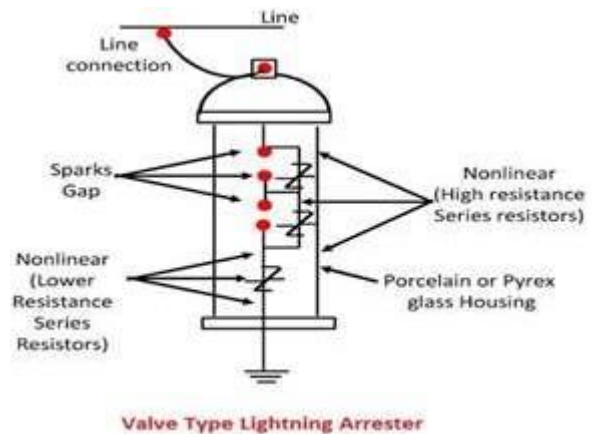

(i) The spark gap is a multiple assembly consisting of a number of identical spark gaps in Each gap consists of two electrodes with a fixed gap spacing. The voltage distribution across the gaps is linearised by means of additional resistance elements (called grading resistors) across the gaps. The spacing of the series gaps is such that it will withstand the normal circuit voltage. However, an overvoltage will cause the gap to breakdown, causing the surge current to ground via the non-linear resistors.

(ii) The non-linear resistor discs are made of an inorganic compound such as Thyrite or Metrosil. These discs are connected in series. The non-linear resistors have the property of offering a high resistance to current flow when normal system voltage is applied, but a low resistance to the flow of high-surge currents. In other words, the resistance of these non-linear elements decreases with the increase in current through them and vice-versa.

Working: Under normal conditions, the normal system voltage is insufficient to cause the breakdown of air gap assembly. On the occurrence of an overvoltage, the breakdown of the series spark gap takes place and the surge current is conducted to earth via the non-linear resistors. Since the magnitude of surge current is very large, the non-linear elements will offer a very low resistance to the passage of surge. The result is that the surge will rapidly go to earth instead of being sent back over the line. When the surge is over, the non-linear resistors assume high resistance to stop the flow of current.

Advantages

- They provide very effective protection (especially for transformers and cables) against
- They operate very rapidly taking less than a second.
- The impulse ratio is practically unity.

Limitations

- They may fail to check the surges of very steep wave front from reaching the terminal This calls for additional steps to check steep-fronted waves.
- Their performance is adversely affected by the entry of moisture into the enclosure. This necessitates effective sealing of the enclosure at all times.

Applications

According to their application, the valve type arresters are classified as (i) station type and (ii) line type. The station type arresters are generally used for the protection of important equipment in power stations operating on voltages upto 220 kV or higher. The line type arresters are also used for stations handling voltages upto 66 kV

Working of Valve Type Lightning Arrester

During the slow voltage variations, there is no sparks-over across the gap. But when the rapid change in voltage occurs, the potential is no longer evenly graded across the series gap. The influence of unbalancing capacitance between the sparks gaps and the ground prevails over the grounded resistance. The impulse voltage is mainly concentrated on the upper spark gap which in spark over cause the complete arrester to spark over to.

For low voltage, there is no spark-over across the gaps due to the effect of parallel resistor. The slow changes in applied voltage are not injurious to the system. But when the rapid changes in voltage occur across the terminal of the arrester the air gap spark of the current is discharged to ground through the non-linear resistor which offers very small resistance.

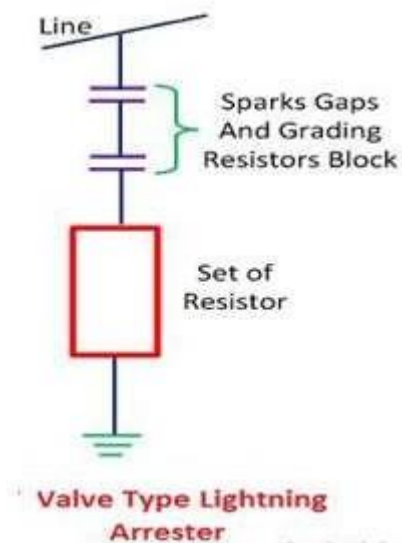

After the passage of the surge, the impressed voltage across the arrester falls, and the arrester resistance increases until the normal voltage restores. When the surge diverter disappears, a small current at low power frequency flow in the path produced by the flash over. This current is known as the power follow current.

The magnitude of the power follows current decreases to the value which can be interrupted by the spark gap as they recover their dielectric strength. The power follow current is extinguished at the first current and the supply remains uninterrupted. The arrester is ready for the normal operation. This is called resealing of the lightning arrester.

Types of Valve Type Lightning Arrester

The valve type lightning arrester may be station types, line types, arresters for the protection of the rotating machine distribution type or secondary type.

Station Type Valve Lightning Arrester – This type of valve is mainly employed for the protection of the critical power equipment in the circuit of 2.2kV to 400kV and higher. They have the high capacity of energy dissipation.

Line Type Lightning Arrester – The line type arresters are used for the protection of substation equipment. Their cross-sectional area is smaller, lighter in weight and cheaper in cost. They permit higher surge voltage across their terminal in comparison to station type and have lower surge carrying capacity.

Distribution arrester – Such type of arrester is usually mounted on the pole and are employed for the protection of the generators and motors

Surge Absorber:

The travelling waves set up on the transmission lines by the surges may reach the terminals apparatus and cause damage to it. The amount of damage caused not only depends upon the amplitude of the surge but also upon the steepness of its wave front. The steeper the wave front of the surge, the more the damage caused to the equipment. In order to reduce the steepness of the wave front of a surge, we generally use Surge Absorber.

A surge absorber is a protective device which reduces the steepness of wave front of a surge by absorbing surge energy.

Although both surge diverter and surge absorber eliminate the surge, the manner in which it is done is different in the two devices. The surge diverter diverts the surge to earth but the surge absorber absorbs the surge energy. A few cases of surge absorption are discussed below :

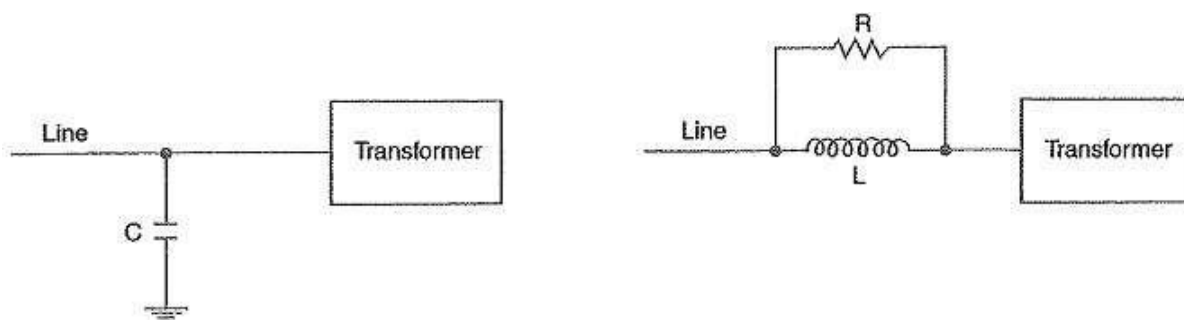

Fig-(a)

Fig-(b)

(i) A condenser connected between the line and earth can act as a surge absorber. The above Fig-(a). shows how a capacitor acts as surge absorber to protect the transformer winding. Since the reactance of a condenser is inversely proportional to frequency, it will be low at high frequency and high at low frequency. Since the surges are of high frequency, the capacitor acts as a short circuit and passes them directly to earth. However, for power frequency, the reactance of the capacitor is very high and practically no current flows to the ground.

(ii) Another type of surge absorber consists of a parallel combination of choke and resistance connected in series with the line as shown in Fig-(b). The choke offers high reactance to surge frequencies ($X_L=2\pi fL$). The surges are, therefore, forced to flow through the resistance R where they are dissipated.

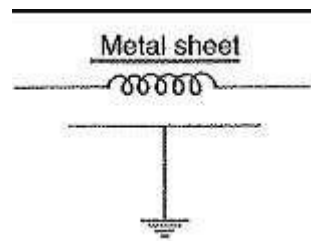

Fig-(c)

(iii) Fig-(c) shows the another type of surge absorber. It is called Ferranti surge absorber. It consists of an air cored inductor connected in series with the line. The inductor is surrounded by but insulated from an earthed metallic sheet called dissipator. This arrangement is equivalent to a transformer with short-circuited secondary. The inductor forms the primary whereas the dissipator forms the short-circuited secondary. The energy of the surge is used up in the form of heat generated in the dissipator due to transformer action. This type of surge absorber is mainly used for the protection of transformers.

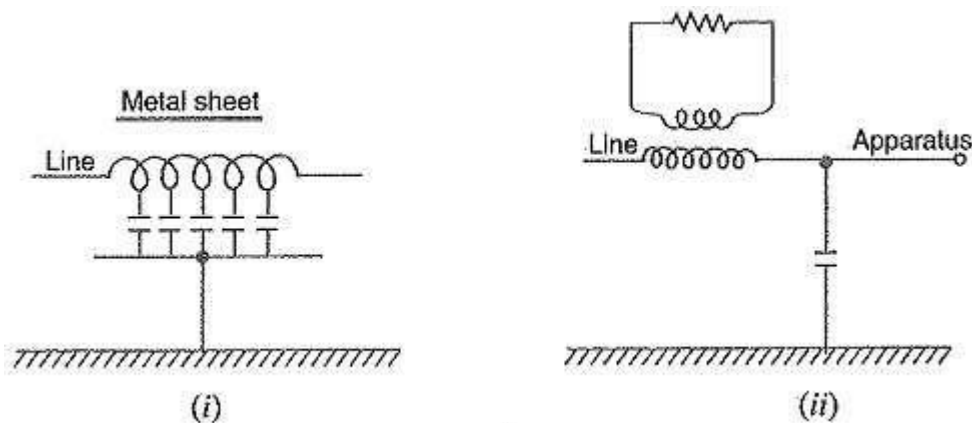

Fig.(i) shows the schematic diagram of 66 kV Ferranti surge absorber while Fig.(ii) shows its equivalent circuit.

Chapter VIII

Static Relay

Definition: The relay which does not contain any moving parts is known as the static relay. In such type of relays, the output is obtained by the static components like magnetic and electronic circuit etc. The relay which consists static and electromagnetic relay is also called static relay because the static units obtain the response and the electromagnetic relay is only used for switching operation.

The component of the static relay is shown in the Fig-8.1 below. The input of the current transformer is connected to the transmission line, and their output is given to the rectifier. The rectifier was rectifying the input signal and pass it to the relaying measuring unit.

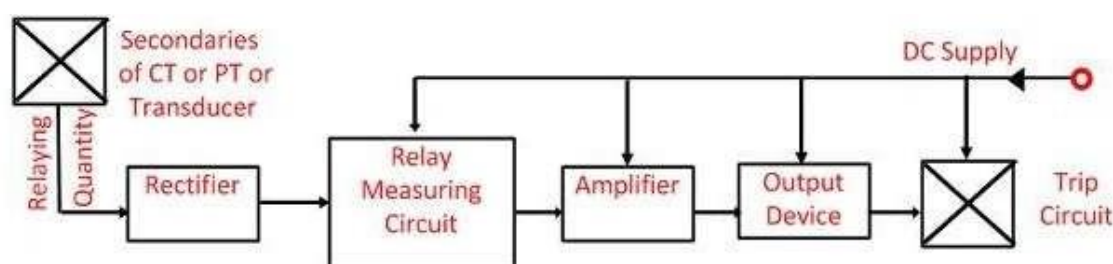

Block Diagram of Static Relay

Fig-8.1

The rectifying measuring unit has the comparators, level detector and the logic circuit. The output signal from relaying unit obtains only when the signal reaches the threshold value. The output of the relaying measuring unit acts as an input to the amplifier.

The amplifier amplifies the signal and gives the output to the output devices. The output device activates the trip coil only when the relay operates. The output is obtained from the output devices only when the measurand has the well-defined value. The output device is activated and gives the tripping command to the trip circuit.

The static relay only gives the response to the electrical signal. The other physical quantities like heat temperature etc. is first converted into the analogue and digital electrical signal and then act as an input for the relay.

ADVANTAGES OF STATIC RELAY

The following are the benefits of static relays.

1. The static relay consumes very less power because of which the burden on the measuring instruments decreases and their accuracy increases.
2. The static relay gives the quick response, long life, high reliability and accuracy and it is shockproof.
3. The reset time of the relay is very less.
4. It does not have any thermal storage problems.
5. The relay amplifies the input signal which increases their sensitivity.
6. The chance of unwanted tripping is less in this relay.
7. The static relay can easily operate in earthquake-prone areas because they have high resistance to shock.

LIMITATIONS OF STATIC RELAY

1. The components used by the static relay are very sensitive to the electrostatic discharges. The electrostatic discharges mean sudden flows of electrons between the charged objects. Thus special maintenance is provided to the components so that it does not affect by the electrostatic discharges.
2. The relay is easily affected by the high voltage surges. Thus, precaution should be taken for avoiding the damages through voltage spikes.
3. The working of the relay depends on the electrical components.
4. The relay has less overloading capacity.
5. The static relay is more costly as compared to the electromagnetic relay.
6. The construction of the relay is easily affected by the surrounding interference.

For integrated protection and monitoring systems programmable microprocessor controlled static relays are preferred.

OVER CURRENT RELAYS

Working Principle of Over Current Relay

In an over current relay, there would be essentially a current coil. When normal current flows through this coil, the magnetic effect generated by the coil is not sufficient to move the moving element of the relay, as in this condition the restraining force is greater than deflecting force. But when the current through the coil increased, the magnetic effect increases, and after certain level of current, the deflecting force generated by the magnetic effect of the coil, crosses the restraining force, as a result, the moving element starts moving to change the contact position in the relay.

Although there are different types of over current relays but basic working principle of over current relay is more or less same for all.

Types of Over Current Relay

Depending upon time of operation, there are various types of Over Current relays, such as,

1. Instantaneous over current relay.
2. Definite time over current relay.
3. Inverse time over current relay.

Inverse time over current relay or simply inverse OC relay is again subdivided as inverse definite minimum time (IDMT), very inverse time, extremely inverse time over current relay or OC relay.

Instantaneous Over Current Relay

Instantaneous Over Current Relay.

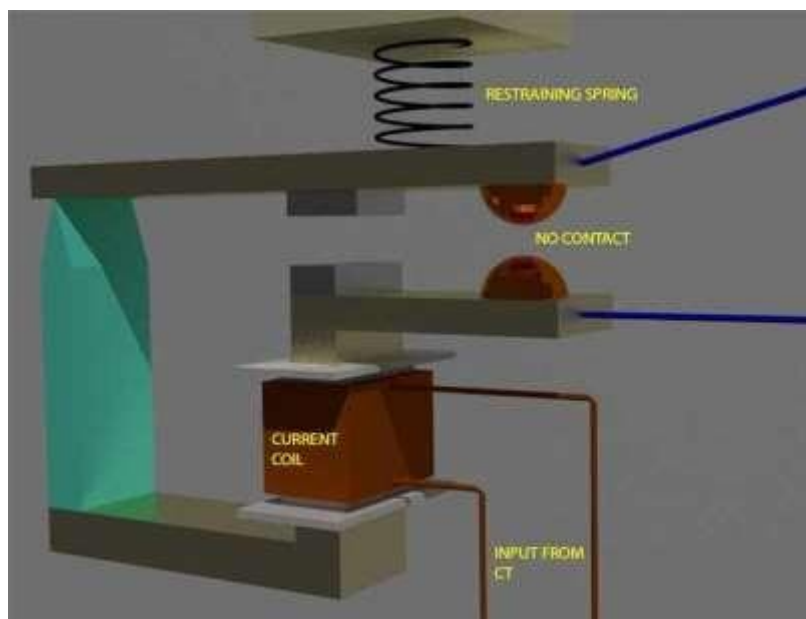

Here generally a magnetic core is wound by current coil. A piece of iron is so fitted by hinge support and restraining spring in the relay, that when there is not sufficient current in the coil, the NO contacts remain open. When current in the coil crosses a present value, the attractive force becomes sufficient to pull the iron piece towards the magnetic core and consequently the no contacts are closed.

The preset value of current in the relay coil is referred as pick up setting current. This relay is referred as instantaneous over current relay, as ideally, the relay operates as soon as the current in the coil gets higher than pick up setting current. There is no intentional time delay applied. But there is always an inherent time delay which can not be avoided practically. In practice the operating time of an instantaneous relay is of the order of a few milliseconds. Fig.

Definite Time Over Current Relay

This relay is created by applying intentional time delay after crossing pick up value of the current. A definite time over current relay can be adjusted to issue a trip output at definite amount of time after it picks up. Thus, it has a time setting adjustment and pick up adjustment.

Inverse Time Over Current Relay

Inverse time is a natural character of any induction type rotating device. This means the speed of rotation of rotating part of the device is faster if input current is increased. In other words, time of

operation inversely varies with input current. This natural characteristic of electromechanical induction disc relay is very suitable for over current protection. This is because, in this relay, if fault is more severe, it would be cleared more faster. Although time inverse characteristic is inherent to electromechanical induction disc relay, but the same characteristic can be achieved in microprocessor based relay also by proper programming.

Inverse Definite Minimum Time Over Current Relay or IDMT O/C Relay

Ideal inverse time characteristics can not be achieved, in an over current relay. As the current in the system increases, the secondary current of the current transformer is increased proportionally. The secondary current is fed to the relay current coil. But when the CT becomes saturated, there would not be further proportional increase of CT secondary current with increased system current. From this phenomenon it is clear that from a certain value to certain range of faulty level, an inverse time relay shows exact inverse characteristic. But after this level of fault, the CT becomes saturated and relay current does not increase further with increasing faulty level of the system. As the relay current is not increased further, there would not be any further reduction in time of operation in the relay. This time is referred as minimum time of operation. Hence, the characteristic is inverse in the initial part, which tends to a definite minimum operating time as the current becomes very high. That is why the relay is referred as inverse definite minimum time over current relay or simply IDMT relay.

